



ATH 2800 M/MT - ATH 3200 M/MT Turbopumps

Operating instructions

ATH 2800 M/MT - ATH 3200 M/MT Turbopumps

Welcome

Dear Customer,

You have just purchased an adixen Magnetically levitated turbopump. We would like to thank you and are proud to count you as one of our customers.

This product has benefited from adixen Vacuum Products many years of experience in the field of turbopump design.



This pumping component is designed to generate vacuum by pumping on gases, but no liquids neither solids. It is dedicated for running in industrial environments.

The integrator of this component must provide all operator safety measures mainly against hot surfaces.

This pumping component must not operate in an area with risk of explosion. Consult us to study a solution.

Applications:

Semiconductor applications, Plasma etching, Ion implantation, Sputtering, Plasma deposition.

Other Applications:

Research and development, High energy physics, Space simulation, Accelerators.

Advantages:

High throughput - Quiet and clean vacuum - Corrosion proof - High MTBF - Minimum size, volume and weight - Smart and compact electronic controller - Reliability - Maintenance free - Battery free - Easy integration.

This operating manual includes only the instructions to connect the maglev pump to the equipment. Refer to the controller operating manual to power and use the pump (chapters B, C and D).

In order to ensure the best possible performance of the equipment and your complete satisfaction in using it, we advise you to read this manual carefully before any intervention on your pump and to pay particular attention to the equipment installation and start-up section.

ATH 2800 M/MT - ATH 3200 M/MT Turbopumps

This product complies with the requirements of European Directives, listed in the Declaration of Conformity contained in G 100 of the controller's operating instructions.

Copyright/Intellectual property:

The use of adixen products are subject to copyright and intellectual property rights in force in any jurisdiction.

All rights reserved, including copying this document in whole or any part without prior written authorization from adixen Vacuum Products.

Specifications and information are subject to change without notice by adixen Vacuum Products.

ATH 2800 M/MT - ATH 3200 M/MT operating instructions

Translated from original version

Chapter A

INTRODUCTION

- A 150 - Introduction to the ATH 2800 M/MT- ATH 3200 M/MT pumps
- A 200 - Control loop of the pump
- A 210 - The pump operating principle
- A 400 - Technical characteristics of the pumps
- A 510 - The accessories of the pumps
- A 515 - Accessory dimensions

Chapter B

START-UP

- B 100 - Safety instructions for installation
- B 201 - Unpacking and storage of the pump
- B 300 - Pump connections to an installation
- B 310 - Inlet and exhaust connections
- B 330 - Nitrogen purge and air inlet valve device connections
- B 340 - Water cooling connection
- B 401 - Typical electrical wiring diagram

Chapter C

OPERATION

- C 100 - Safety instructions for product use

Chapter D

MAINTENANCE

- D 100 - Safety instructions for product removal
- D 150 - Maintenance frequency

Chapter E

MAINTENANCE INSTRUCTIONS

- E 50 - Replacement of the water valve coil
- E 100 - Shipping procedure for contaminated pumps

Chapter F

MAINTENANCE COMPONENTS

- F 000 - Spare parts - Instructions of use
- F 200 - First level maintenance parts

Chapter G

APPENDIX

- G 150 - Pumping curves
- G 200 - Service

CAUTION

Indicates a potentially hazardous situation which, if not avoided, could result in property damage.

CAUTION

Indicates a potentially hazardous situation which, if not avoided, could result in moderate or minor injury. It may also be used to alert against unsafe practices.

WARNING

Indicates a potentially hazardous situation which, if not avoided, could result in death or severe injury.

ATH 2800 M/MT - ATH 3200 M/MT operating instructions

Translated from original version











⚠ DANGER

Indicates an imminently hazardous situation that, if not avoided, will result in death or severe injury (extreme situations).

Before switching on the product, study the Operating instructions and make sure you follow the safety instructions it gives. You can recognise these by the 'Caution', 'Warning' and 'Danger' symbols.
 Good practice tips and manufacturer's recommendations are in a blue box.

The performance and operational safety of this product are guaranteed provided it is used normally in the operating conditions defined in this manual. It is the customer's task to:

- train operators to use the product if they do not speak the language the manual is written in,
- ensure operators know the safe practices to apply when using the product.

Symbols, labels	Description
	Warning : hot surface
	Warning : hazardous voltage
	Caution : risk of danger. Refer to the operating instructions before use
	ON
	OFF
	Do not touch when the pump is running
	Use of glove is recommended
	Moving parts present
	Heavy object
	Electrical connector locking
Purge	Purge port
Pump exhaust	Exhaust of the pump
Water	Water cooling circuit connection
Water max Pr.7 bar/101 psi	Max. cooling water pressure
	Direction of rotation of the pump



Introduction

ATH 2800 M/MT - ATH 3200 M/MT Operating instructions Detailed contents

A 150 *Introduction to the ATH 2800 M/MT, ATH 3200 M/MT pumps*

A 200 *Control loop of the pump*

- 5 active axis
- Unbalanced force rejection control

A 210 *The pump operating principle*

- Pumping principle
- The hybrid-turbo pump in an installation
- The back-up ball bearings
- No maintenance
- Battery free
- Variation of the pump rotational speed

A 400 *Technical characteristics of the pumps*

A 510 *The accessories of the pumps*

A 515 *Accessory dimensions*

Introduction to ATH 2800 M/MT - ATH 3200M/MT pumps

**A magnetically
levitated turbopump**



Five active axes

Rotor position control in 5 directions.

Unbalanced Force Rejection Control

Lowest possible levels of noise and vibration.

Automatic adjustment to any imbalance of the rotor, from very low speed.

Maintenance free

Inert gas purge

Protects from corrosion the magnetic spindle.

Battery free

In case of a power failure, the pump motor acts like a generator to transform the rotor energy into electrical power to supply the controller.

MT models

Integrated band heater

Maintaining the pumps internal surface up to 75 °C to prevent the condensation effect.

Temperature regulated by the controller. The MT versions are supplied with a water valve.

Controller

The ATH 2800 M/MT and ATH 3200 M/MT pumps work with OBC controller or with the MAGPOWER controller. (refer to the operating instructions corresponding).

Control loop of the pump

5 active axis

The mobile assembly formed by the turbo rotor and the shaft is known as the rotor. The rotor is driven by the motor and held in suspension by magnetic fields generated by electromagnets housed in an active bearing.

The mobile rotor has 5 axes of freedom monitored by 5 active magnetic bearings.

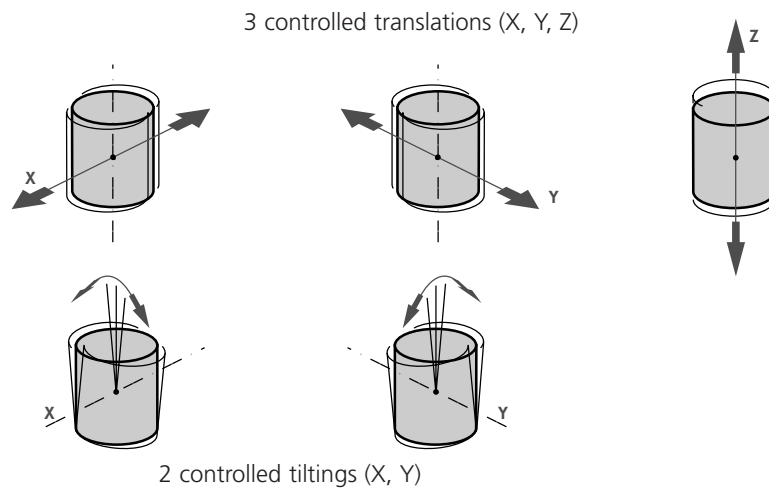

Movements in relation to these axes are monitored by position sensors. According to the position data recorded, the controller corrects differences to bring the rotor back to its optimum position, by varying the current in electro-magnets.

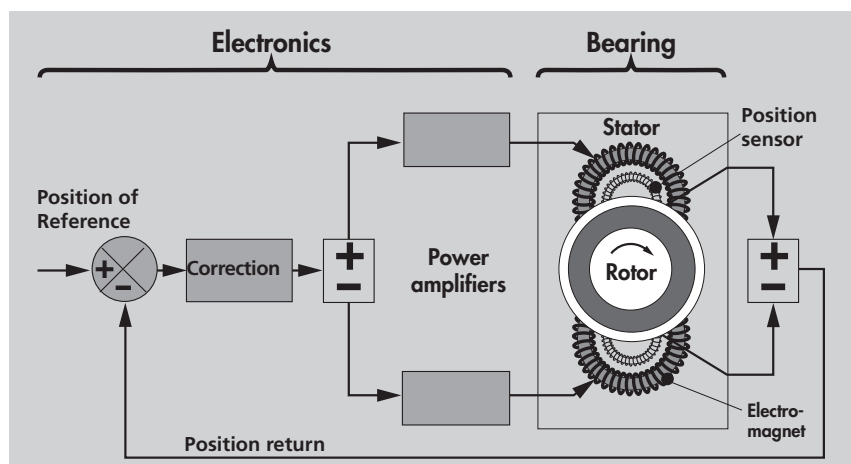

Control loop of the pump

Unbalanced force rejection control

The **unbalanced force rejection control** is an electronic function, that monitors the rotor position, allowing it to rotate in its own axis of inertia.

Changes in the rotor balance, due to deposit built-up during the life time of the pump, are automatically compensated by the **unbalanced force rejection control**.

It ensures the lowest possible levels of noise and vibration.

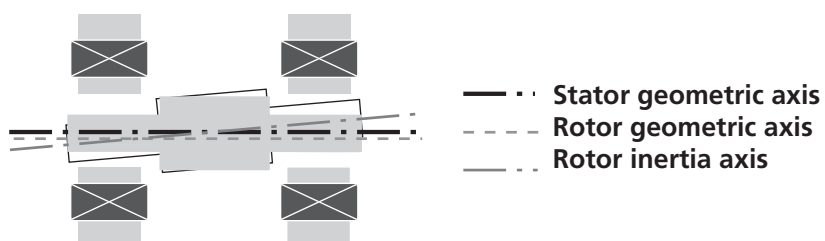

The pump operating principle

Pumping principle The ATHM pump integrates the advantages of a multi-staged turbomolecular pump with a spiral helix molecular drag section.

The turbomolecular section provides high pumping speeds and high ultimate vacuum. The molecular drag section provides a high compression ratio and extends forevacuum tolerance.

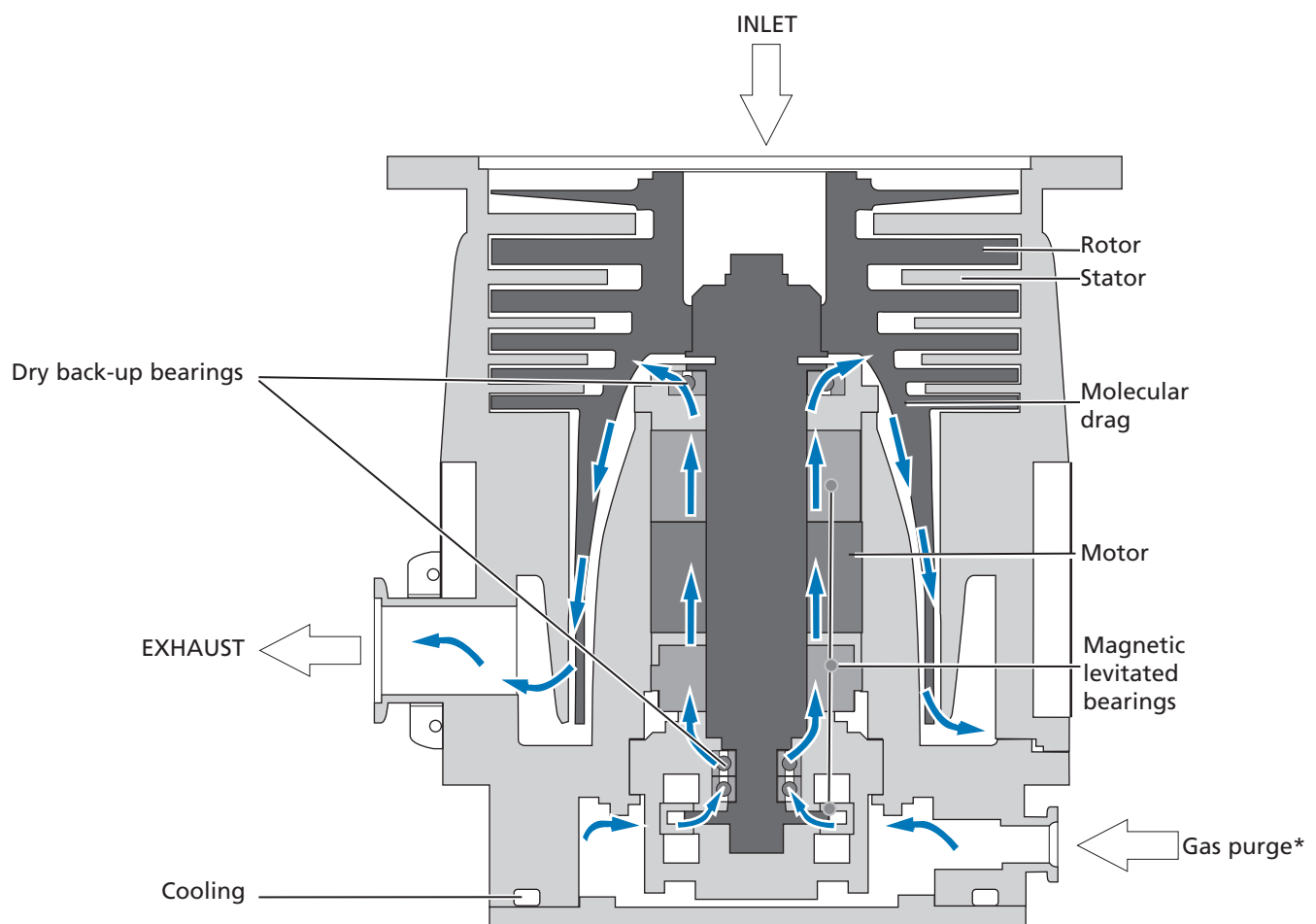

* The gas purge provides an excellent protection of the maglev bearings for corrosive applications and ensures the rotor cooling.

The pump operating principle

The hybrid-turbopump in an installation

At the pump exhaust, the gases are evacuated to atmosphere by a primary pump.
The ATHM compression ratio is set by the design. The pumping performances depend of the primary pump and of the installation.

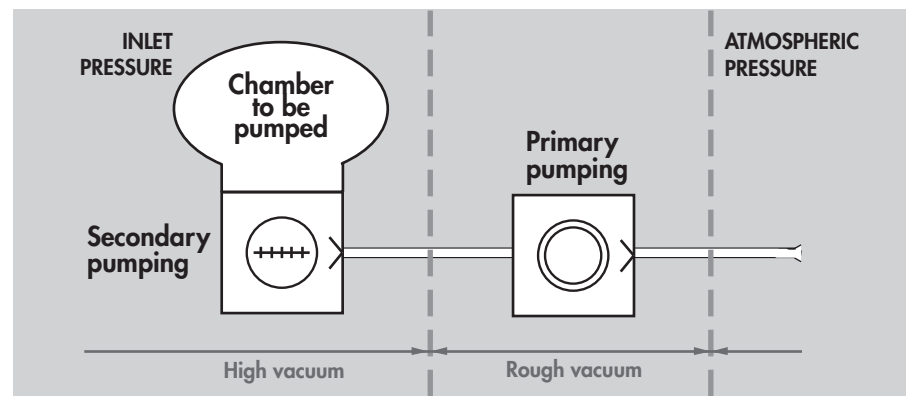

The built-in heater band (on MT model)

At high pressure and high throughput processes such as metal etch, deposit can build up in the lower compression stages of the rotor, leading the pump to early failure.

The built-in heater band allows pump heating up to 75 °C, which is sufficient to avoid the condensation effect. This device is controlled by the controller. The MT version must be equipped with its water valve (the water valve is supplied with the MT model).

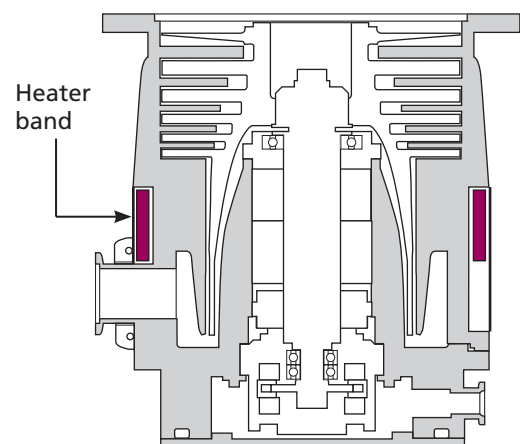

The pump operating principle

The back-up ball bearings

They are dry-lubricated ceramic ball bearings. They are never used in normal operation, since the rotor is not in contact with the ball bearings. The back-up ball bearings are only used to protect the pump in accidental air in-rushes, accidental shocks or power failure.

No maintenance

By design, the pump doesn't include parts liable to wear and doesn't need preventive maintenance. However, the back-up ball bearings used in case of accidental shut-downs have to be changed when the controller indicates it: the percentage of landing time to be deducted depends on the number of incidents. The maximum life time of the rotor is described in  **D 150**.

Battery free

In case of a power failure, the motor acts like a generator, supplying enough power for the magnetic bearings. When the rotation speed is too low, the pump shuts down and lands on the back-up ball bearings.

Variation of the pump rotational speed

The ATHM pump rotation speed can be selected and set between a minimum speed and the maximum speed. This makes it possible to optimize pumping characteristics according to each customer application (for example, high pressure pumping).

A distinction is made between the following speeds:

- **reduced speed (STANDBY speed)** which can be set between the low speed value and the nominal speed.
- **nominal speed** preselected at factory.

Technical characteristics of the pumps

The performances of the pumps

CHARACTERISTICS		UNITS	ATH 2800 M	ATH 2800 MT	ATH 3200 M	ATH 3200 MT
Flange (in)			DN 250 ISO F / VG 250		DN 320 ISO F / VG 350	
Flange (out)			DN 40 ISO KF (DN 50 ISO KF optional)			
Pumping speed*	Ar	l/s	2100		2700	
	H2	l/s	1550		1700	
	He	l/s	2400		2500	
	N2	l/s	2200		2800	
Compression ratio	Ar		> 1 · 10 ⁸			
	H2		> 2 · 10 ³			
	He		> 3 · 10 ⁴			
	N2		> 1 · 10 ⁸			
Gas throughput ^{(1) (2)}	Ar	sccm	2200	700	2200	700
	H2	sccm	> 5000	> 1000	> 5000	> 1000
	He	sccm	> 5000	> 1000	> 5000	> 1000
	N2	sccm	5000	1000	5000	1000
Fore vacuum max. ⁽³⁾	Ar	hPa	2.8			
	H2	hPa	0.4			
	He	hPa	1.3			
	N2	hPa	2.1			
Inlet vacuum max. ⁽²⁾	AR	hPa	0.026	0.006	0.026	0.006
	N2	hPa	0.26	0.01	0.26	0.01
Ultimate pressure ⁽⁴⁾		hPa	< 6 · 10 ⁻⁹			
Nominal rotation speed		rpm (Hz)	25 000 (417)			
Standby speed		rpm (Hz)	From 15 000 (250) to nominal speed 25 000 (417)			
Sound pressure level		db(A)	< 45			
Pump protection index			IP 42			
Controller power supply		V AC	200-240			
Leak tightness		hPa·l/s	< 5 · 10 ⁻⁸			
Max. start-up power **		W	< 1 100	< 1 500	< 1 100	< 1 500
Power consumption at ultimate pressure		W	< 130	< 520	< 130	< 520
Standby power		W	< 100	< 350	< 100	< 350
Max. apparent start-up power **		VA	< 1 800	< 2 100	< 1 800	< 2 100
Mounting orientation			Any			
Maximum heating temperature		°C	-	75	-	75
Heating power of the heating band (the same input voltage as the controller)		W	-	380	-	380
N2 purge flange			DN16 ISO-KF			

* Without inlet screen.

** With the Magpower controller.

⁽¹⁾ At nominal rotational speed, water temperature = 25 °C (M = cold ; MT = 65 °C).

⁽²⁾ With a low exhaust pressure, depends on external conditions (water temperature, water flow, ambient temperature).

⁽³⁾ With ratio inlet pressure/exhaust pressure >100, max. throughput reduced.

⁽⁴⁾ With ISO-K, ISO-F flange ; better with CFF flange.

Technical characteristics of the pumps

The performances of the pumps

CHARACTERISTICS	UNITS	ATH 2800 M	ATH 2800 MT	ATH3200 M	ATH3200 MT
Run-up time up to 90% of nominal rotation speed, with exhaust pressure < 0.1 hPa **	min	< 10			
Maximum baking temperature	°C	120			
Recommended purge flow rate	sccm	50			
Vibration level at nominal speed	µm	< 0.01			
Maximum leakage current ⁽⁵⁾	mA	< 12			
Maximum water line pressure	hPa	7 · 10 ³			
Weight of the pump	kg	85		82	
Recommended backing pump	-	adixen ADP / ADS			
Cooling water flow rate	l/h	> 60			
Water temperature ⁽⁶⁾	°C	15 < T < 40	15 < T < 25	15 < T < 40	15 < T < 25
Environmental conditions : - Ambient operating temperature - Use of the product - Maximum altitude - Accept transient over voltages typically present on the main supply - Pollution degree applicable - Maximum relative humidity ⁽⁷⁾	°C - m/ft - - -	5 < T < 45 5 < T < 25 5 < T < 45 5 < T < 25 Indoor only 2000 / 6562 Category II 2 80 %			
Three phase motor characteristics (Max. values) : Voltage between phases Supply frequency Phase current	 Vrms Hz A	 35 834 17.5			

** With the Magpower controller.

⁽⁵⁾ Not all leakage current is necessarily evacuated through the earth wire ; it depends on the pump earth connect regarding the equipment to which the pump is connected.

⁽⁶⁾ > 25 °C : apply a derating on continuous max flow. Change the operating conditions to reduce the nominal power. Contact the Customer Service.

⁽⁷⁾ Maximum relative humidity 80 % for temperatures up to 31 °C, decreasing linearly to 50 % relative humidity at 40 °C.

A 400

Technical characteristics of the pumps

ATH 2800 M/MT Dimensions

**HEATED VERSION
(MT model)**

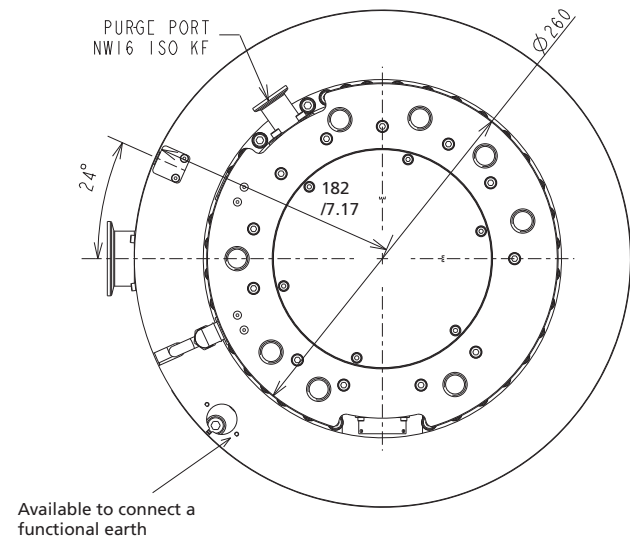
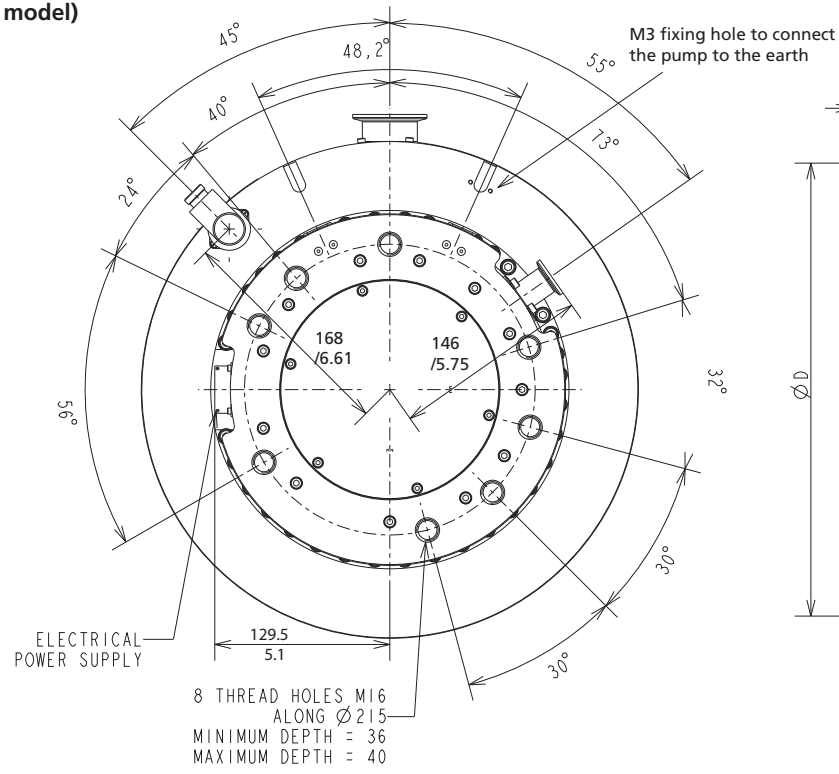

**UNHEATED VERSION
(M model)**

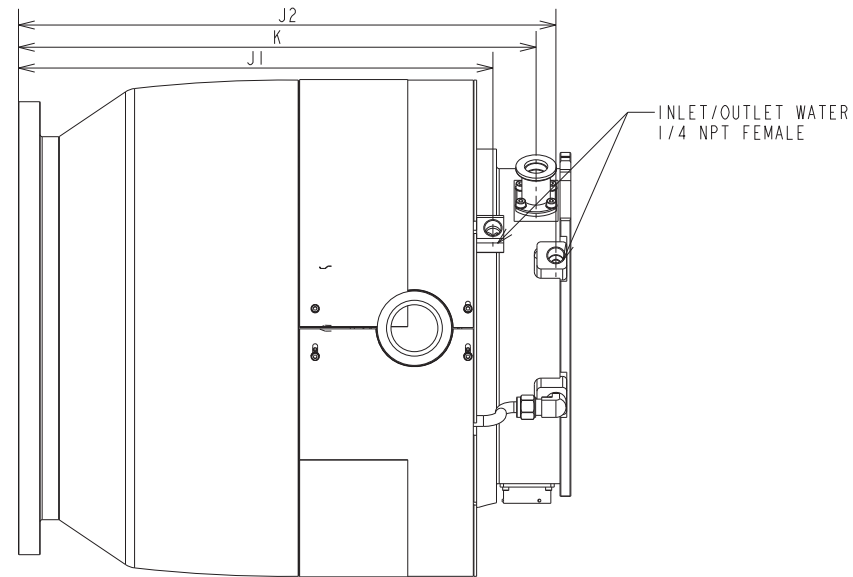
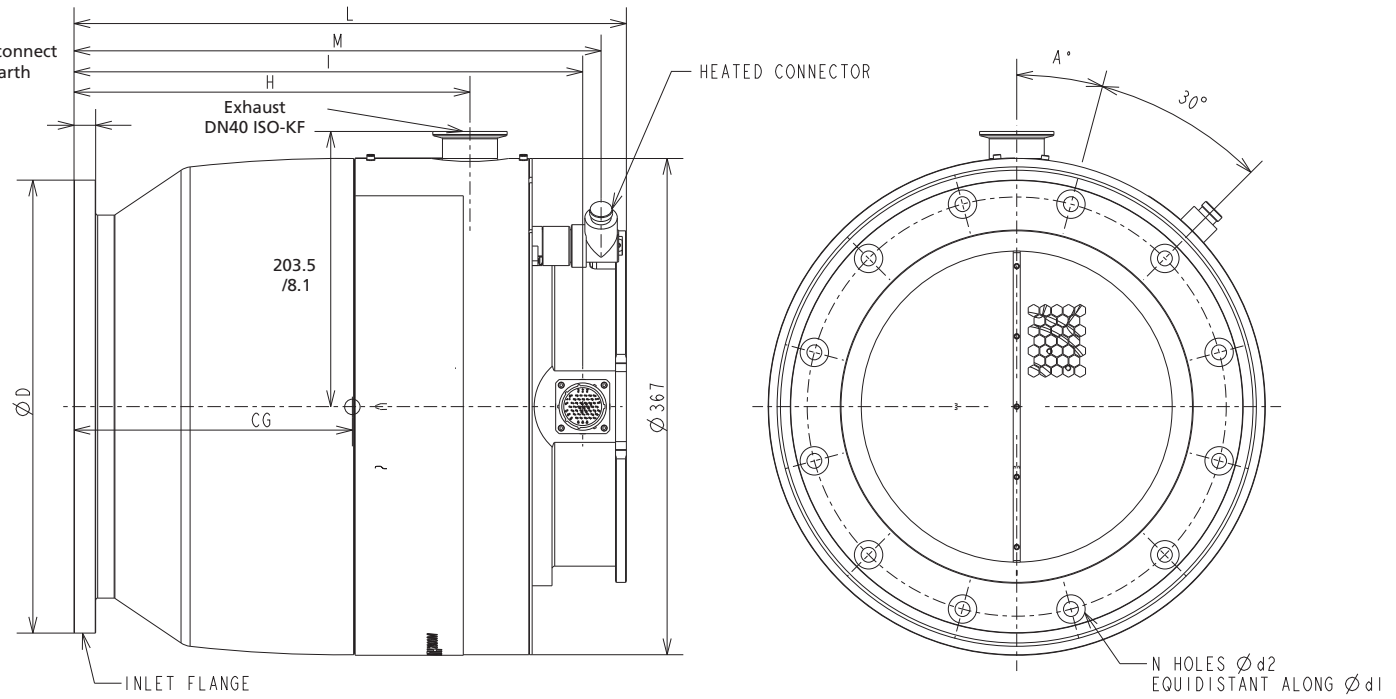

Dimensions in mm / inch

Inlet flange	E	H	I	J1	J2	K	L	M	D	d1	d2	N	A°	CG
DN 250 ISO-F	16,00 / 0,63	292,90 / 11,54	376,30 / 14,83	351,00 / 13,83	398,00 / 15,68	382,90 / 15,09	408,60 / 16,10	389,90 / 15,36	335,00 / 13,20	310,00 / 12,21	11,00 / 0,43	12	15	206,30 / 8,13
VG 250	16,00 / 0,63	292,90 / 11,54	376,30 / 14,83	351,00 / 13,83	398,00 / 15,68	382,90 / 15,09	408,60 / 16,10	389,90 / 15,36	350,00 / 13,79	320,00 / 12,61	15,00 / 0,59	12	15	204,00 / 8,04

A 400

Technical characteristics of the pumps

ATH 3200 M/MT Dimensions

HEATED VERSION (MT model)

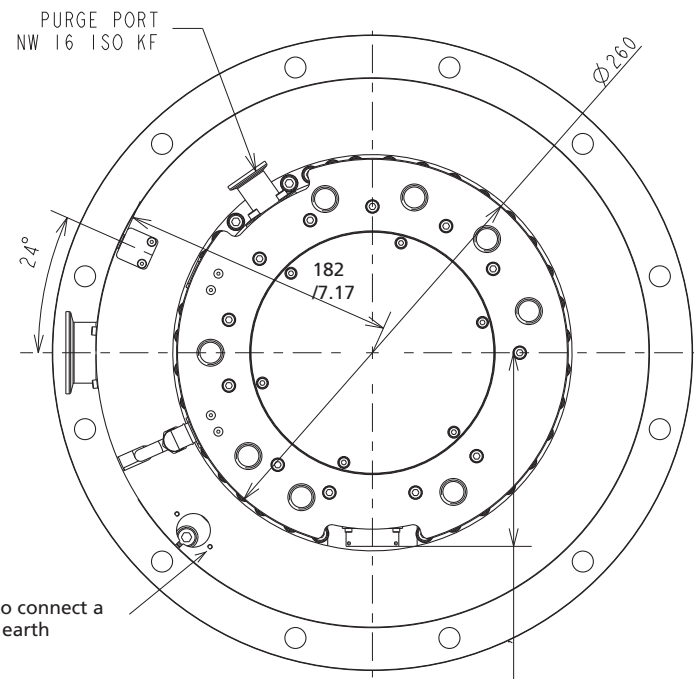
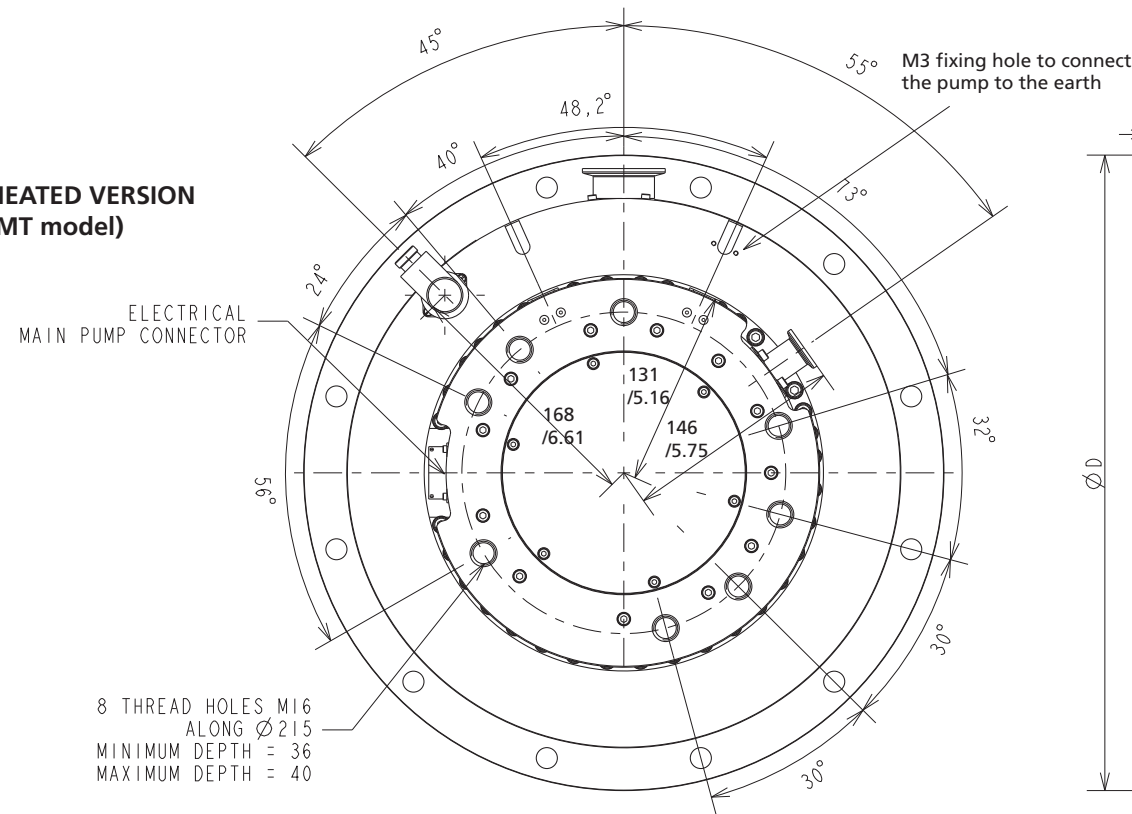

UNHEATED VERSION (M model)

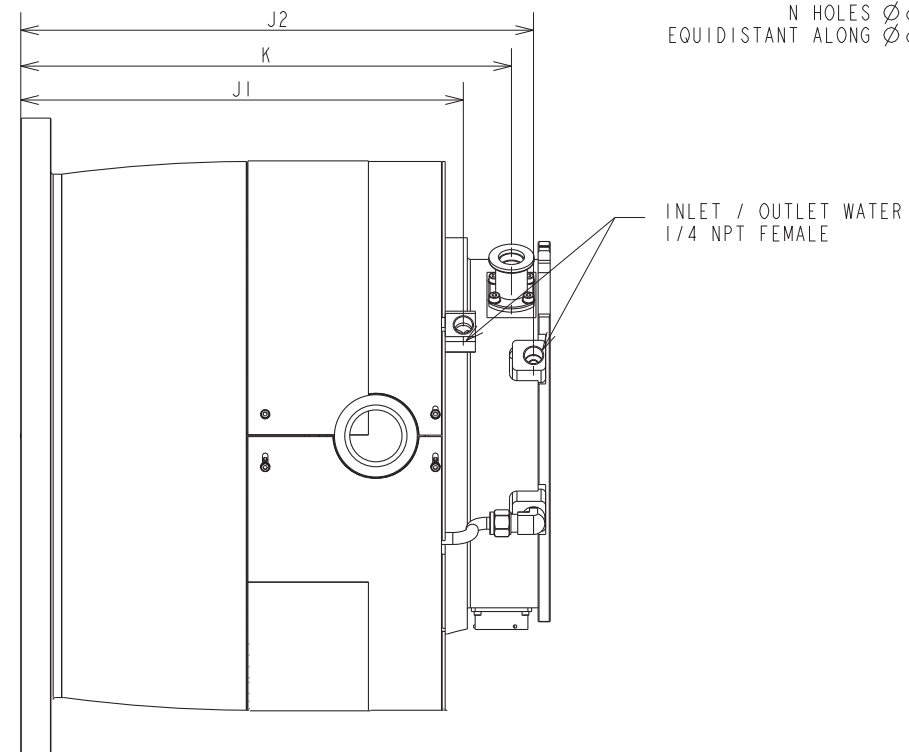
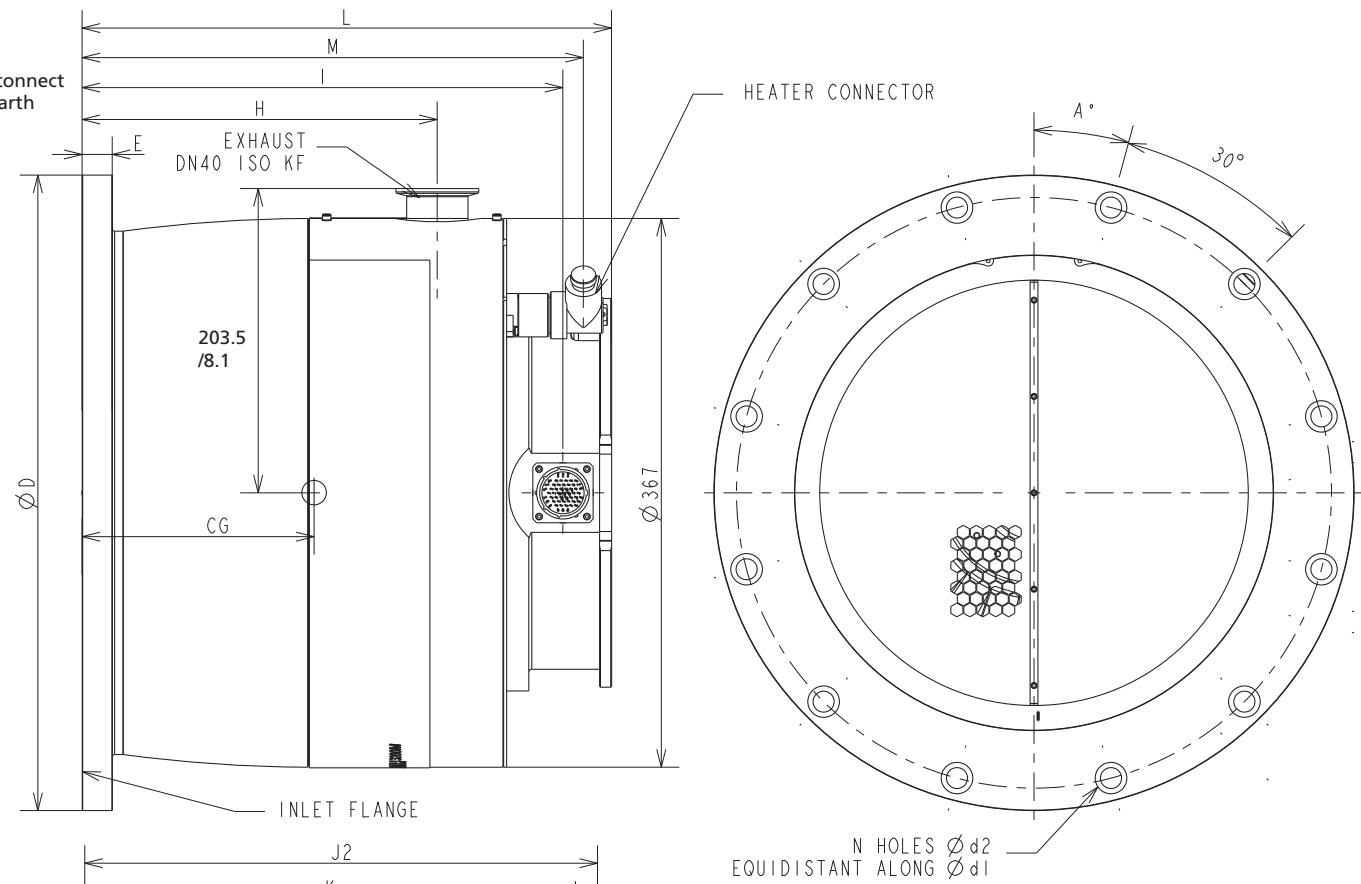

Dimensions in mm / inch

Inlet flange	E	H	I	J1	J2	K	L	M	D	d1	d2	N	A°	CG
DN 320 ISO-F	20 /0,79	235,7 /9,29	319,1 /12,57	293,8 /11,58	340,4 /13,41	325,7 /12,83	351,4 /13,85	332,7 /13,11	425 /16,75	395 /15,56	13,5 /0,53	12	15	152,9 /6,02
VG 350	20 /0,79	235,7 /9,29	319,1 /12,57	293,8 /11,58	340,4 /13,41	325,7 /12,83	351,4 /13,85	332,7 /13,11	450 /17,73	420 /16,55	15 /0,59	12	15	149,9 /5,91

The accessories of the pump

This screen protects the pump against solid particles. It is integrated into the pump housing.

DN 250 (S. Steel)	P/N
Bent screen + bored clip (mesh size 8 mm)	112128
DN 320 (S.Steel)	P/N
Bent screen + bored clip (mesh size 8 mm)	112132
VG 350 (S.Steel)	P/N
Bent screen + bored clip	114683

Purge flow reduction device	This device is used to reduce the purge gas flow rate in some processes.	Flow Reduction device	P/N
		DN 16 50 SCCM	066752

Isolation valve at inlet pump	The secondary isolation valve is used to maintain the vacuum in the chamber while the pump is reset to atmospheric pressure.	See the Manufacturer's catalog.
--------------------------------------	--	---------------------------------

Water valve	The water valve is used to regulate the water flow. The water valve is connected to the controller with the thermostatic cable. ( A 500 in the controller Operating instructions.	Water valve	P/N
		24 VDC	108668

Bolt and washer kit for pump installation

Pumps	DN	P/N for ISO F	P/N for VG	Description
ATH 2800	250	110675 110676S	-	12 CHC M10x30 12 CHC M10x35*
ATH 3200	320	113189	-	12 CHC M12x45
	350	-	113189	12 CHC M12x45

* With centering ring

The accessories of the pump

**Purge valve (50 sccm)
(operate only by the
customer tool) ***

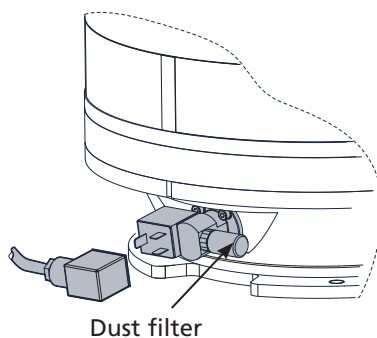

Purge valve	P/N
24 VDC	111921S

The purge flow warrants a gas flushing for back-up ball bearing protection from the pumped process gases.

The purge of this valve can be isolated during an air tightness test.

Air inlet valve *

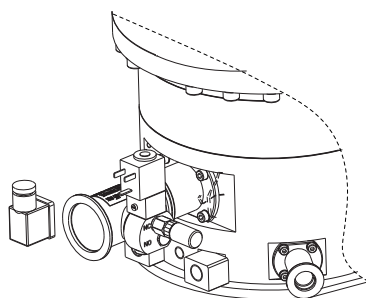

Air inlet valve	P/N
24 VDC	114280

The air inlet valve, powered by the controller, is installed on the pump exhaust port. It allows to reduce the braking time of the pump to put it at the atmospheric pressure. It is a NC valve which is activated when the pump nominal speed is below 10 000 rpm.

* Provide a power line compatible with extra low voltage and safety standards (SELV).

**Air inlet valve cables and
purge valve cables
(for pumps controlled by
Magpower)**

Length	P/N
1 m	A462403-010
3.5 m	A462403-035
5 m	A462403-050
10 m	A462403-100
20 m	A462403-200

The accessories of the pump

Thermostatic cable for (MT Models)

Length	P/N
1 m	A460082-010
3.5 m	A460082-035
5 m	A460082-050
10 m	A460082-100
20 m	A460082-200

Water valve cable

Length	P/N
1 m	A462401-010
3.5 m	A462401-035
5 m	A462401-050
10 m	A462401-100
20 m	A462401-200

An entire range of connection accessories is available in the catalog (clamping ring, centering ring, etc.).

Accessory dimensions

Purge valve (50 sccm)
dimensions mm (*inch*)

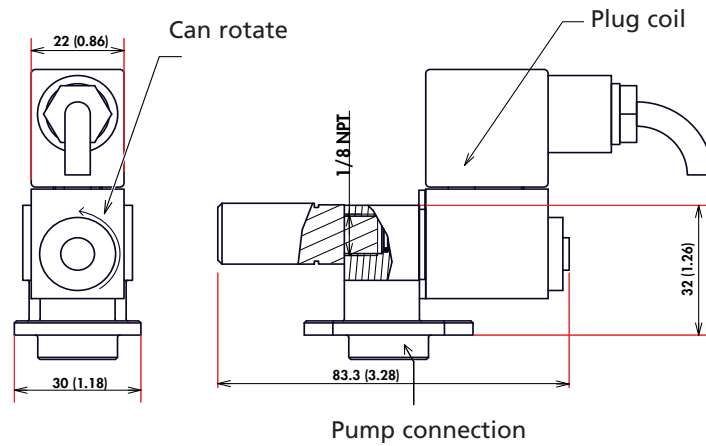

Air inlet valve
dimensions
mm (*inch*)

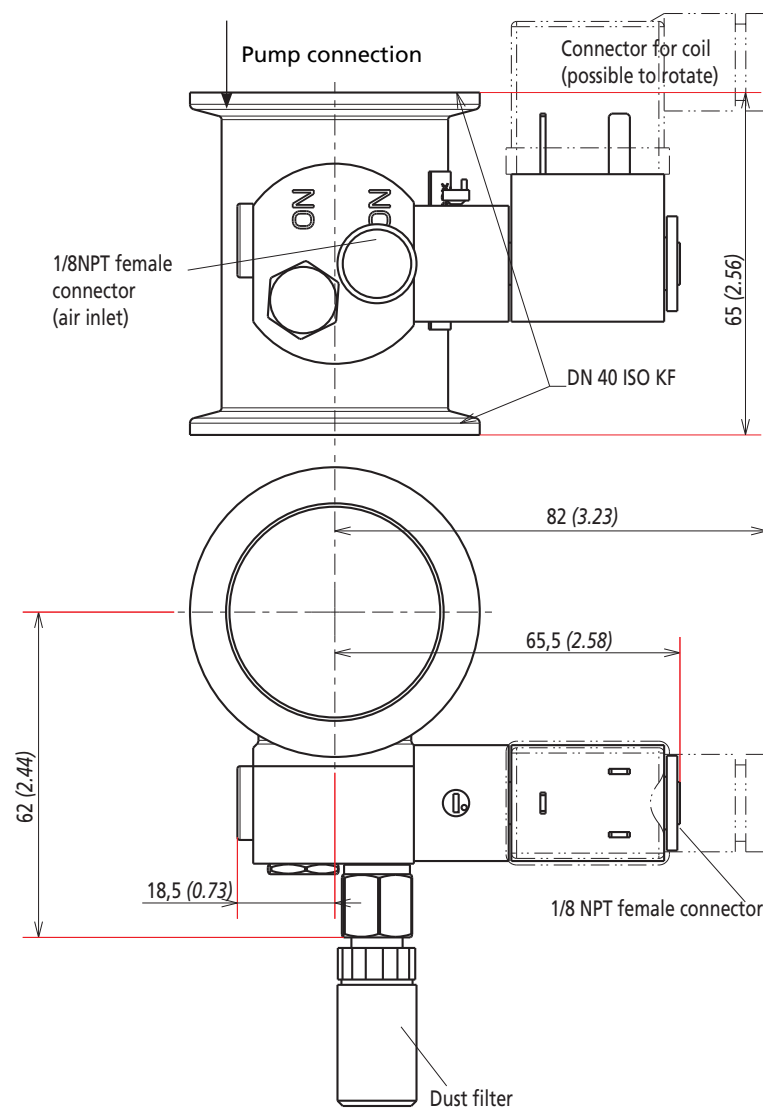

Accessory dimensions

Water valve
dimensions
mm (inch)

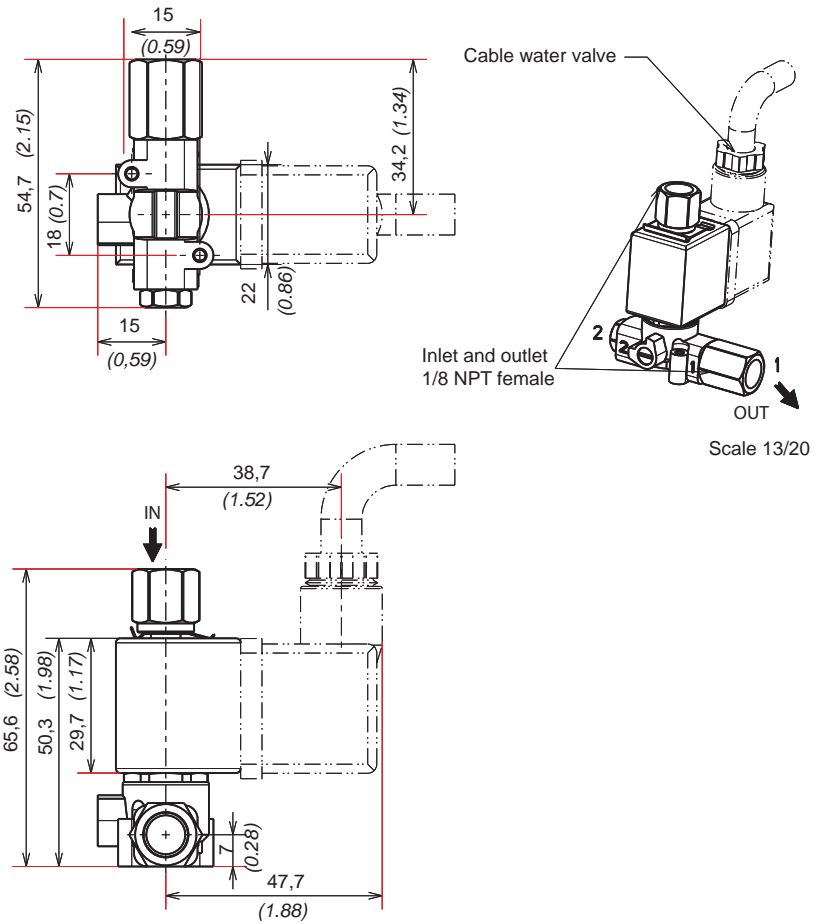



Start-up

ATH 2800 M/MT - ATH 3200 M/MT Operating instructions Detailed contents

B 100

Safety instructions for installation

B 201

Unpacking and storage of the pump

B 300

Pump connections to an installation

- Equipment installation conditions
- Pump connection instructions
- Why securing pump installation ?
- Worst Case Turbo Pump Crash Scenario Definitions

B 310

Inlet and exhaust connections

B 330

Nitrogen purge and air inlet valve device connections

- Characteristics of filtered dry nitrogen supply
- Purge device (50 sccm)
- Valve with purge device (50 sccm)
- Air inlet valve

B 340

Water cooling connection

- Characteristics of water cooling

B 401

Typical electrical wiring diagram

Safety instructions for pump and controller installation

CAUTION	Indicates a potentially hazardous situation which, if not avoided, could result in property damage.
⚠ CAUTION	Indicates a potentially hazardous situation which, if not avoided, could result in moderate or minor injury. It may also be used to alert against unsafe practices.
⚠ WARNING	Indicates a potentially hazardous situation which, if not avoided, could result in death or severe injury.
⚠ DANGER	Indicates an imminently hazardous situation that, if not avoided, will result in death or severe injury (extreme situations).

Overview

Before switching on the product, study the Operating instructions and make sure you follow the safety instructions. You can recognise these by the 'Caution', 'Warning' and 'Danger' symbols.
 Good practice tips and manufacturer's recommendations are in a blue box.

The performance and operational safety of this product are guaranteed provided it is used normally in the operating conditions defined in this manual.
 It is the customer's task to:

- train operators to use the product if they do not speak the language the manual is written in,
- ensure operators know the safe practices to apply when using the product.

We took care to provide you with a clean product. To keep it in this condition, unpack it only in contamination free area and at final place of use.

For emergencies

For emergencies and breakdowns, contact the manager of your local service center (see addresses at back of operating instructions or on our website).

Make sure the equipment shows no sign of transport damage. If it has been damaged, take the necessary steps to record this with the carrier and inform the manufacturer. In all cases, we recommend keeping the packaging (reusable materials) for further transport of the equipment or for prolonged storage.

Safety instructions for pump and controller installation

The turbomolecular pumps can't evacuate at atmospheric pressure, they are connected to a roughing pump. For a transient period, they can start to run at atmospheric pressure.

Our products are designed to comply with current EEC regulations. Users making their own modifications to the product are liable to break its compliance with these regulations, degrade its EMC (electromagnetic compatibility) rating, and make it unsafe to use. The manufacturer declines all liability for the consequences of such operations.

WARNING

Do not expose any part of the human body to vacuum. The product is supplied with the inlet and exhaust sealed. Remove these blanking plates when you are ready to connect the product on your vacuum system. As well as, don't operate the product unless the inlet and exhaust are connected to a vacuum and exhaust pumping line.

Handling

WARNING

■ **Heavy product:**
This product needs special handling precautions due to its weight. It should be removed from its crate only by staff trained in heavy materials handling:

- use the lifting rings provided with the product,
- use slings from a length over 500 mm.
- tighten the pump to the handling device.

The maker can not be held liable for the consequences of using other rings.

■ **Risk of tilting:** although the product meets EEC safety regulations, it is advisable to guard against the risk of tilting during handling, installation, and use. ( chapter A for the location of the center of gravity).

Installation

DANGER

■ **Pump connection to the installation:**
It is strongly recommended to secure the maglev turbopump installation to prevent any safety hazard to the user in standard operating conditions : ( B 300).

■ **Risk of cut injury:**
The access to the rotor of a turbomolecular pump with an unconnected inlet port is dangerous. In the meantime, if the pump is not switched on, it may be driven by another pump in operation.
Always connect the pump inlet port before starting the pump.

CAUTION

Make sure all parts and chambers connected to the inlet, exhaust and purge of the maglev pump can withstand a negative pressure of 100 kPa below atmospheric pressure and that they are impervious to damage from vacuum (seals, etc.).

Safety instructions for pump and controller installation

Installation (cont'd)

WARNING

The user and /or OEM are ultimately responsible for operating the equipment in a safe manner. The manufacturer has no control over the types of gases exposed to this pump. This is the user and/or the OEM's responsibility to follow the necessary safety requirements. Frequently process gases are toxic, flammable, corrosive, explosive and/ or otherwise reactive. Toxic gases can cause serious injury or death. Operators and users must take the appropriate safety recommendations to prevent injury. Consult the responsible department for instructions and safety information. Hazardous gases through the pump can cause serious injury or death. It's mandatory by regulations to connect the turbomolecular pump's exhaust to a rough pumping line compatible with the process gases. Check that pump is correctly connected to the equipment ( B 310).

DANGER

■ If any corrosive, reactive, flammable, pyrophoric, oxidizing process gases can be sent to the pump, then an exhaust extraction system monitor should be used to ensure that gas flow to the pump is stopped when exhaust gas extraction system is lost.

If flammable materials are sent to the pump, the customer will need to provide a hardware based LEL detection in the exhaust extraction system (detection capability at 25 % of the LEL) that will stop chemical supply to the pump when gas is detected over 25 % of LEL for that flammable material.

■ For non clean process.

If loss of purge flow creates a significant risk, then the purge flow must be monitored externally and a response to loss of purge flow must be provided by the process equipment and interlocked.

If pyrophoric materials above the LEL (lower explosive limit) are sent to the pump then nitrogen should be supplied at a rate to ensure that concentration is diluted to be below the LEL, in addition an interlock should be provided to

CAUTION

■ The product's EMC rating is obtained on the understanding that it is installed in compliance with EMC rules.

Specially: in environments that are prone to emit interference, use shielded cables and connections on interfaces.

■ Ensure that the product is connected to an electrical installation:

- in compliance with the local and national safety requirements,
- equipped with electrical protection (fuses, circuit breaker, ...) which has a suitable earth (ground) point, properly connected.

■ This pump is not equipped with a lock out/tag out (LO/TO) device because it is designed for use on process tools.

In order to properly secure the pump for installation or/and maintenance,

the entire tool needs to be properly locked-out/tagged out in accordance with OSHA requirement 29 CFR.1910.147.

■ If access to the IEC connector is restricted an additional isolation device should be provided, which will be easily accessible by an operator.

Safety instructions for pump and controller installation

Installation (cont'd)

WARNING

■ Electric shock hazard.

The voltages and currents in use can induce electric shock.

Isolate and lock out power line to the product before maintaining it /or removing the cover.

Only skilled, authorized people may carry out maintenance work.

If a main isolator is installed by the customer, it must be in compliance with local regulations, with a minimum interrupting short circuit current of 10kA.

■ Electric shock hazard.

Some components have capacitors charged to over 60 VDC, or motor operating as generator. When power is switched off, they keep their charge for a time. Take precautions concerning the access to the connector pins. Wait at least 5 minutes after the pump comes to complete stop before starting any work.

■ Other located hazardous energies.

Water cooling circuit and nitrogen purge are pressurized hazardous energies.

Release pressure before servicing:

1 - for the N₂ purge, disconnect the gas line ;

2 - for the water cooling circuit, disconnect the input connector and leave the output connected. Don't forget to put a vessel (≥ 1 l) under the water output.

■ Operation in local mode

There is no device to warn that the pump operates in local mode. When the pump is not integrated in the equipment/host tool, the user must provide a device to warn that the pump operates in local mode.

■ The products are factory tested to ensure they will not leak in normal operating conditions. It is the user's responsibility to ensure this level of leak tightness is maintained.

■ Specific operating conditions may exist that require extra caution from users due to the high temperatures generated (outer surfaces > 70 °C):
Wear protective gloves and leave the pump to cool before working on the product.

Safety instructions for pump and controller installation

Installation (cont'd)

DANGER

Safety interlock.

The pump motor is protected against overload through the drive «start/stop» and enable control circuitry of the variable speed controller. The drive start/stop includes solid state components. If hazards due to accidental contact with moving machinery or unintentional flow of liquid, gas or solids exist, an additional hardwired stop circuit is required to remove input power.

It is never required to override this interlock during installation, use or maintenance.

Once activated power will be switched off and the pump will be put in a safe condition. When a fault occurs, the cause must be corrected before the fault can be cleared. It is required to switch power off and on to clear the fault.

CAUTION

■ If the product is used in applications where solid particles or condensable gases are present, we advise on avoiding any deposition into the pumping line. Contact our customer service.

■ The manufacturer guarantees the right operation of the pump if it is used in a uniform magnetic field up to 0.5 mT.

From 0.5 to 5 mT the limit of the right operation depends on the cooling and the gas loads.

Exceeding 5 mT can cause excessive rotor heating due to the eddy current. It is therefore necessary to provide suitable shielding in such cases.

The pump standalone is resistant to radiation at levels up to 10^3 Gy.

■ The units containing control circuits are designed to guarantee normal safety conditions taking their normal operating environment into account (use in rack).

In specific cases of use on tables, make sure that no objects enter the ventilation openings or block the openings when handling the units.

■ Protection against foreign bodies

Controller can be deteriorated when any objects are introduced or any liquids penetrate into the unit.

Make sure no objects enter through the ventilation holes. Keep the unit away from the liquids.

Safety instructions for pump and controller installation

Labels stuck on the product

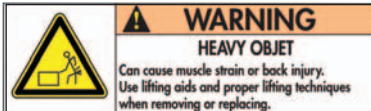

This label indicates that handling the pump can cause muscle strain or back injury. For all product handling, use the appropriate handling devices.

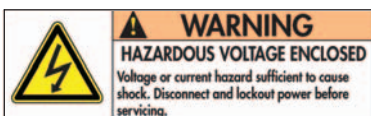

This label indicates that some of the internal parts are energized and could cause electrical shocks in case of contact. It advises to disconnect the pump before any intervention or to properly lock-out and tag-out the equipment breaker before any intervention on the pump.



This label warns the user against possible risk of injury due to any hand contact with hot surfaces. It states that protective gloves should be used before performing any intervention.

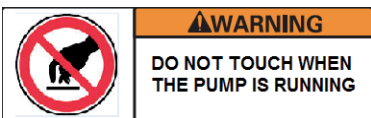

Avoid causing a shock on a pump when the rotor is moving, it can block the right operation.



This label means that you must lock the electrical connector before using the pump and during operation.

Other labels

Customer is in charge to stick these labels on the ATHM on the most appropriate location to warn the operator regarding the probable hazards.



This label informs the user that moving parts present inside the pump could cause personal injury, like crushing or cutting. The user must keep all body parts away from moving parts.

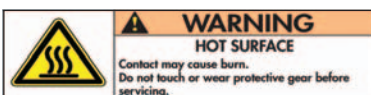

The «hot surface» sticker must be stucked conspicuously on the pump housing.



The user must label visibly the product to warn against pumped process gas that could be dangerous and toxic and could cause severe injuries or death. It precises that any preventive maintenance operation can only be performed by trained personnel.

Unpacking and storage of the pump

Unpacking

Make sure the equipment shows no sign of transport damage. If it has been damaged, take the necessary steps to record this with the carrier and inform the manufacturer. In all cases, we recommend keeping the packaging (reusable materials) for further transport of the equipment or for prolonged storage.

The packaging depends on the configuration of the pump. It can also contain other cardboard boxes for the accessories like: inlet screen, air inlet valve, purge device, high temperature sticker, electric cable...

CAUTION



Pollution risk:

Unclean and contaminated components can increase the pump down time. Use only dry and clean pipe lines, and wear gloves to make the pump connections.

Pump handling



This label indicates that handling the pump can cause muscle strain or back injury.

For all product handling, use the appropriate handling devices.

WARNING

■ Heavy product

This product needs special handling precautions due to its weight. It should be removed from its crate only by staff trained in heavy materials handling:

- use the lifting rings provided with the product,
- use slings from a length over 500 mm.
- tighten the pump to the handling device.

The maker can not be held liable for the consequences of using other rings.

Pump installation with inlet housing facing up: connect the pump to the customer's handling device using the threaded holes located at the rear of the pump (chapter A400 of the Operating instructions).

■ Risk of tilting: although the product meets EEC safety regulations , it is advisable to guard against the risk of tilting during handling, installation, and use (chapter A for the location of the center of gravity).

Pump storage

CAUTION

If you are storing the new pump, keep it wrapped in to its protective film. Our product can be stored in the following conditions:

- in a clean, dry and contamination free environment,
- at an ambient temperature between - 5 °C and + 50 °C,
- for a period of 2 years maximum.

If you need to store a pump which has run on clean process, don't forget to blow out the water line and to purge the pump with N2. Seal the inlet, exhaust and purge ports with blanking plates. Don't store the pump more than 6 months in a clean and dry environment.

Never store a pump which has been used on corrosive process. Return it to a repair service center (E100)

Unpacking and storage of the pump

⚠ WARNING

The product is supplied with the inlet and exhaust blanked off. This prevents foreign bodies entering the pump during transport and storage. Do not remove these blanking plates until you are ready to install the product on the vacuum line.

Inlet ASA, ISO, VG or CF-F blanking flange (depends on the model).

Exhaust Blanked with a DN 40 ISO-KF blanking plates.

Connection for air inlet valve and nitrogen device Blanked with a DN 16 ISO-KF blanking plates.

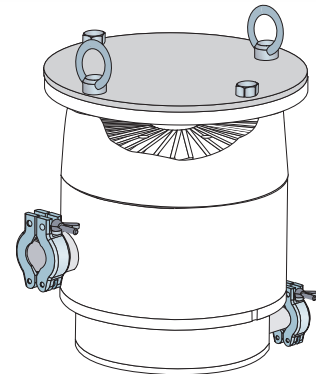

Pump connections to an installation

Equipment installation conditions

⚠ WARNING

The equipment frame on which the pump is installed must be sufficiently rigid to absorb the kinetic energy of the rotor in case of pump rotor crash. For this, take into account :

- the maximum loads to calculate the equipment attachment devices,
- the flange dimensions,
- the quality and the number of bolts.
- Avoid using reducing adaptor or bellows between the pump inlet flange and the chamber.

When the pump is connected according to the manufacturer recommendations (refer to B 300) , in case of overpressure resulting from an incident, the pump enclosure can withstand a maximum static pressure of 1.1 MPa for 1 minute.

⚠ WARNING

Pump installation with inlet housing facing up.
- connect the pump to the customer's handling device using the threaded holes located at the rear of the pump (refer to chapter A 400).

The pump can operate in any position

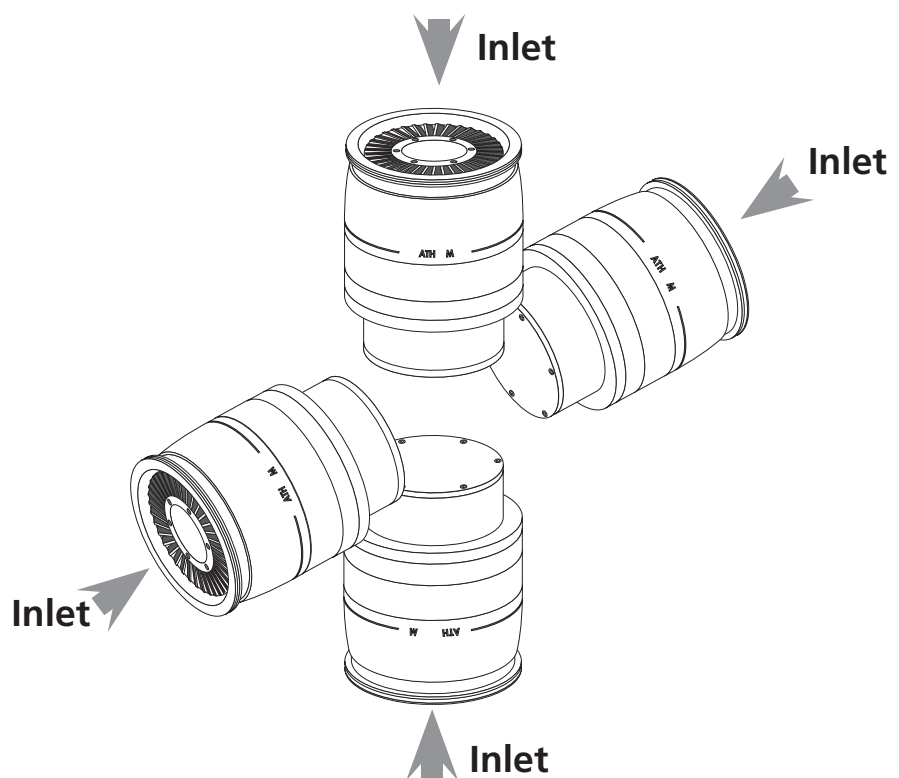

Pump connections to an installation

Pump connection instructions Why securing Pump installation?

Magnetic Turbopumps are designed so as to prevent any safety hazard to the user in standard operating conditions.

However, some operating conditions may generate hazards for the user and the environment : **the kinetic energy stored in a turbopump is very high.** In case of a mechanical failure an improperly installed pump could be ejected from the equipment if the kinetic energy was transferred to the pump body.

⚠ WARNING

It is absolutely necessary to install the pump according to the following installation specifications to secure the user and the equipment.
The constructor declines any responsibility if the pump installation is not designed in accordance with the installation specifications described in this section.

Installations specifications

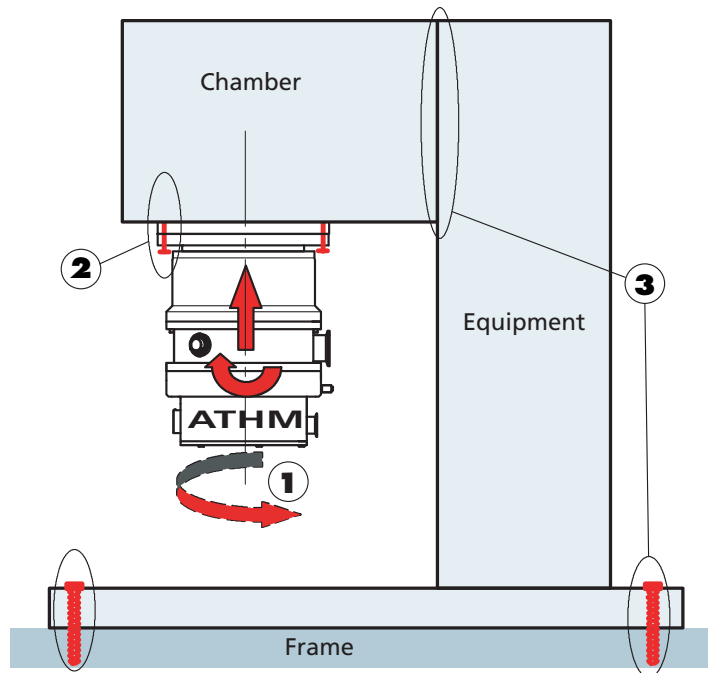

Pump connection instructions

Respect the items 1, 2 and 3.

Pump connections to an installation

Worst Case Turbo Pump Crash Scenario Definitions

The kinetic energy of the rotor has to be absorbed by the installation **if the pump seizes suddenly**.

In the worst case the **rotor splits into 2 parts at nominal speed**. The impact of the rotor parts creates the following **transient loads**.

Bending moment (b)

The impact of the rotor parts on the housing will create a radial force on the housing. This radial force will create a bending moment on the system as a function of the distance to the pump.

Torque (c)

The deceleration of the rotor parts creates a torque value on the pump housing, which is transmitted to the system.

The maximum values of the axial force and the bending moment occur at approximately the same time. A delay of up to several ms has been observed for the maximum torque value.

Loads transmitted to the system (item 1)

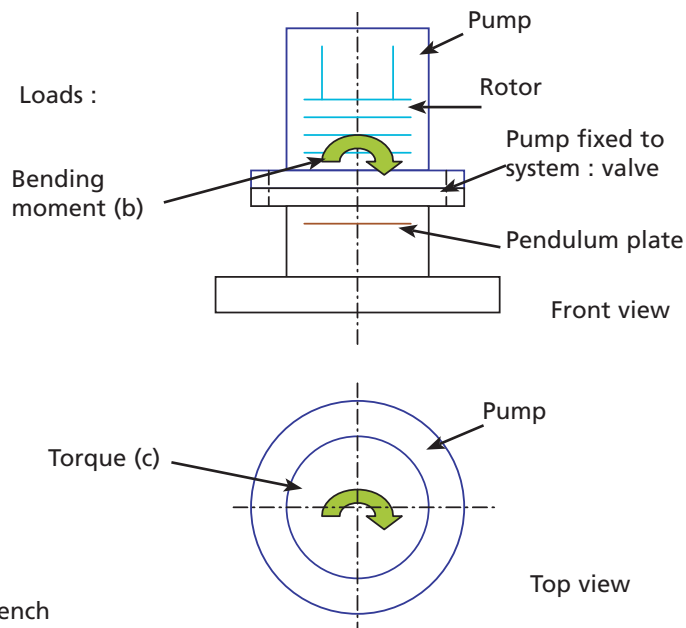

ATH 2800 M - ATH 3200 M
Transmitted forces on Manufacturer's bench

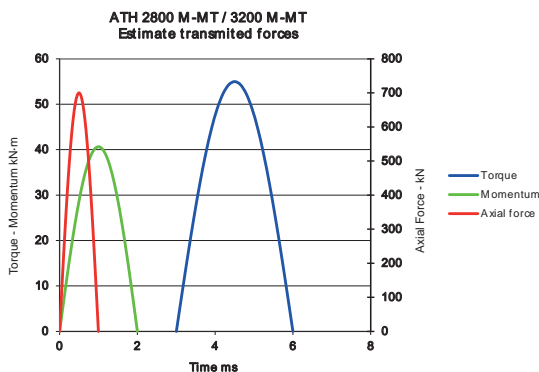

Pump model	Unit	ATH 2800 M ATH 3200 M
Nominal speed	rpm	25 000
Energy	kN·m	166
Torque	Max. kN·m	58
	Duration ms	3
	Delay ms	3
Bending moment	Max. kN·m	40
	Duration ms	2
	Delay ms	0

Pump connections to an installation

Inlet flange installation conditions (item 2)

The resulting maximum loads from a crash have to be taken into account by the pump assembly bolts.

Design and secure the pump frame so that it can withstand the loads.

Mounting holes at inlet flanges	ATH 2800 M			ATH 3200 M		
	DN250 ISO-F with centering ring	DN250 ISO-F without centering ring**	VG 250	DN320 ISO-F with centering ring	DN320 ISO-F without centering ring	VG 350
Inlet flange						
Type of bolts dictated*	M 10	M 10	M 12	M 12	M 12	M 12
Number of bolts dictated*	12	12	12	12	12	12
Length of bolts (mm)	≥ 35	30	≥ 40	≥ 45	40	≥ 45
Bolt metric grade*	12-9	12-9	12-9	12-9	12-9	12-9
Installation torque per bolt (N·m)*	30	30	50	50	50	50
Total clamping force (N)	161 500	161 500	231 500	232 500	232 500	231 500

* type,number, grade and torque are mandatory

** Inlet FLange DN250 ISO-F without ring : only use special bolts with washer delivered for this type of installation (12 bolts and washers kit PN 110034).

DANGER

We strongly recommend the use of ISO-F or VG type flanges. ISO-K type flanges are not recommended to fasten turbomolecular because:

- There is no visual reminder (like threaded holes on ISO-F) to signal how many clamps are needed to secure the pump,
- It is not as easy to fasten claw clamps on ISO-K flanges as to secure bolts on ISO-F flanges,
- The ISO-K flanges do not prevent accidental rotation of the pump on the equipment flange in case of pump rotor crash. This rotation could damage the foreline and the purge gas line which would generate hazards for the user.
- For secure, ISO-K is forbidden on this pump size.

DANGER

For safety reasons, it is important to tighten the bolts with a torque wrench according to the specified values :

- lower torque: risk of loosened bolts
- higher torque: risk of damaging the bolts.

Equipment installation conditions (item 3)

If the equipment cannot withstand the maximum loads in case of rotor crash, please contact the manufacturer for further consultations.

Inlet and exhaust connections

Vacuum connections

WARNING

Do not expose any part of the human body to vacuum.
The product is supplied with the inlet and exhaust sealed. Remove these blanking plates when you are ready to connect the product on your vacuum system.
As well as, don't operate the product unless the inlet and exhaust are connected to a vacuum and exhaust pumping line.

CAUTION

Risk of injury by cutting.
Contact with the pump rotor cell may cause cuts. Alternatively, protective gloves may be worn when servicing the product.

CAUTION

Make sure all parts and chambers connected to the inlet, exhaust and purge of the maglev pump can withstand a negative pressure of 100 kPa below atmospheric pressure and that they are impervious to damage from vacuum (seals, etc...).

CAUTION

For safety reasons, use accessories on the inlet and exhaust lines whose materials and sealing properties are compatible with the gases being used.

Materials in direct contact with process gases

COMPONENTS IN THE PUMP	MATERIALS
From inlet to outlet	Stainless steel, aluminium alloy
O-ring	Fluorinated elastomers, FPM

WARNING

Pump installation with inlet housing facing up:
- connect the pump to the customer's handling device using the threaded holes located at the rear of the pump ( A 400 of the Operating instructions).

CAUTION



Pollution risk:
Unclean and contaminated component can increase the pumping down time. Use only dry and clean pipe lines, and wear gloves to make the pump connections.

After connecting the product to the pumping line, check for leaks along the entire to ensure proper connections.

Inlet and exhaust connections

At inlet: Check that an inlet screen accessory is installed on the pump ; if not, install it. (pumps are delivered with inlet screen filter).
Screen filter

Mounting of the insertable inlet screen

Position the screen (2) into the inlet housing groove (1), bend side opposite to the rotor. Position the ring (3) and press it manually into the groove bottom all over its circumference.

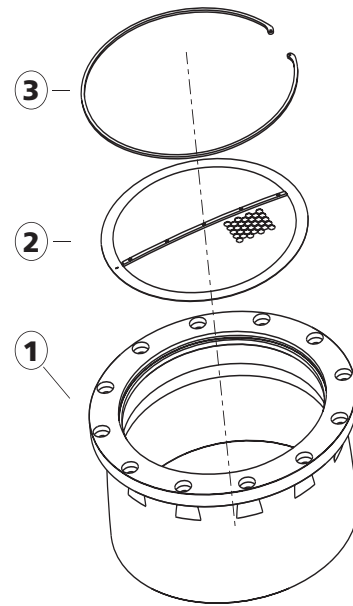
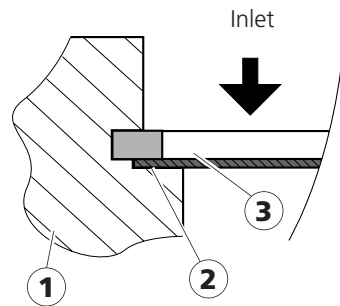

CAUTION

It is recommended to install an isolation valve between the chamber to allow chamber venting without stopping the pump.

At exhaust

The turbomolecular pumps can't evacuate at atmospheric pressure, they are connected to a roughing pump. For a transient period, they can start to run at atmospheric pressure.

WARNING

When pumping on corrosive gases, or aggressive gases, the gas can cause injury or death. The exhaust of the turbopump must be connected to roughing pump line compatible with process gases.

CAUTION

It is highly recommended to install an isolation valve (closed when power is off) between the turbo pump and the roughing circuit.

Nitrogen purge and air inlet valve device connections

Characteristics of filtered dry nitrogen supply

A filtered dry nitrogen supply with the following characteristics is required:

- H₂O concentration : < 1 ppm
- O₂ concentration : 1 ppm
- Dew point < 22 °C
- Dust < 1 μm
- Oil < 0.1 ppm
- Absolute pressure of 100 to 120 kPa.

Purge device for DN16 (50 sccm)

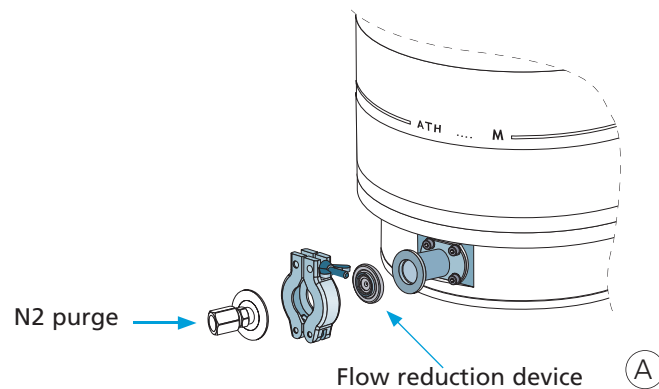
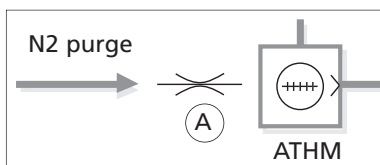

⚠ WARNING

The maximum pressure of the purge must not exceed 200 kPa, to avoid an over pressure of the pump.

The nitrogen purge must be connected directly to the pump exhaust port.

The purge flow is continuous. Connect the nitrogen supply to the DN 16 purge fitting*. The nitrogen flow reduction device controls the pressure and guarantees a flow rate of 50 SCCM at pressure 110 kPa.

Note: N₂ supply can be equipped with a massflowmeter, and in this case, it is not necessary to install the flow reduction device.

Adjust the flow rate

Feed the nitrogen purge throughout pumping according to the flow rate and pressure values in the scale given.

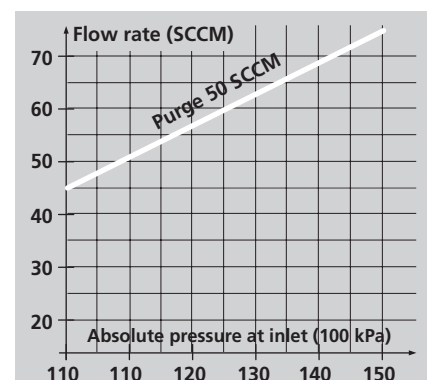

* Different connection accessories can be found in the catalog.

Nitrogen purge and air inlet valve device connections

CAUTION

When the inert gas purge is stopped, the pumped gases can pass from rough vacuum side to high vacuum side and damage the pump bearings. It is advised to maintain the purge flow as long as the rotor is running to protect pump internal parts.

Valve with purge device (50 sccm)

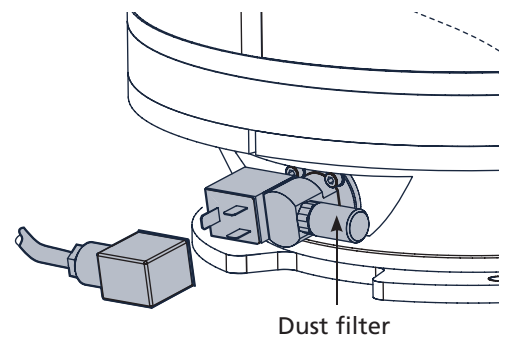
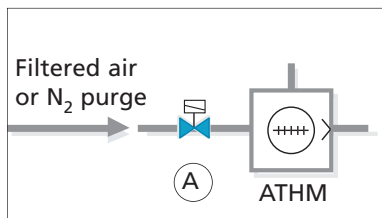

During operation, it's possible to stop the purge, i.e. for tightness test. A nitrogen purge can be connected instead of the dust filter (1/8 NPT female).

CAUTION

Replace regularly the dust filter when used in dusty air.

Air inlet valve

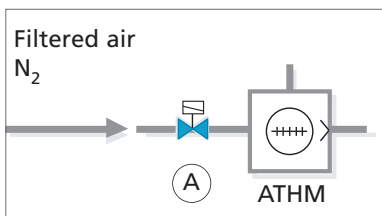

Installed on the pump exhaust, the air inlet valve is calibrated to reset the volume of the pump to atmospheric pressure. When the pump is isolated (at inlet and exhaust) the rotor slow down efficiency is increased. If the venting time is setted, the reset to atmospheric pressure takes place when the pump is stopped or when faults are registered on the controller (📖 operating instructions of the controller).

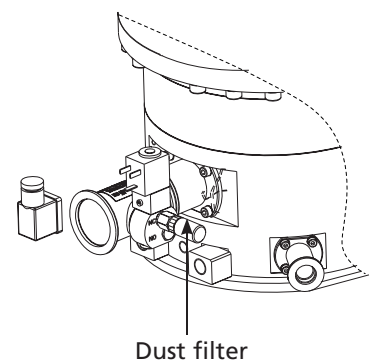

A nitrogen purge can be connected instead of the dust filter (1/8 NPT female).

Water cooling connection

Characteristics of water cooling

In order to avoid corrosion and clogging of the cooling pipes, it is recommended to use cooling water with the following characteristics: treated soft water or non-corrosive industrial water pH between 7.5 and 11

- Hardness: < 7 milli-equivalent/l
= 350 mg/l of CaCO₃ calcium carbonate)
= 35 °F (French degree)
- Resistivity: 1 500 Ω.cm < R < 20 000 Ω.cm
- Solid pollution: < 100 mg/dm³
- Solid particle size (maxi): 0.2 mm
- Pressure maximum: < 700 kPa
- Temperature: 15 °C < T < 40 °C (for M model)
 15 °C < T < 25 °C (for MT model)
- Flow rate: 60 l/h

CAUTION

- In case of water temperature is < 20 °C, there is a risk of condensation.
- The use of uncontrolled city water can lead to water circuit clogging due to limestone deposition, which may necessitate in the worst case a complete cleaning and overhaul of the cooling circuit.
- The presence of micro-organisms like aquatic weed and micro-biological substances like bacteria can lead to cooling problem in the pump. Appropriate water treatment system need to be used to prevent growth of such micro-organisms.

Water line connection

- Clean the male and female fittings: remove dust or traces of thread sealant.
- Apply a pipe thread sealant on the male fittings (Teflon™ tape or chemical sealant product by Loctite™ for example).
- Insert the fitting by hand.
- While holding fitting body steady with a wrench, tighten the fitting with a second wrench.
- Check that there are no leaks.

CAUTION

Water leak risk : maintain the water inlet fitting with a flat wrench during the water line connection (pipe equipped with connector), this to avoid fitting damage.

WARNING

Do not install water fittings above electrical components : there is a risk of electrical discharge in case of a leak at the water fitting connection.

Water cooling connection

For ATH 2800-3200 M models

- Provide a water inlet pipe and a tap to adjust the flow rate.

- Connect the water inlet line to one of the cooler water fittings 1/4 NPT female on the pump, with the other fitting connected to the water draining circuit via a tube (supplied by customer).

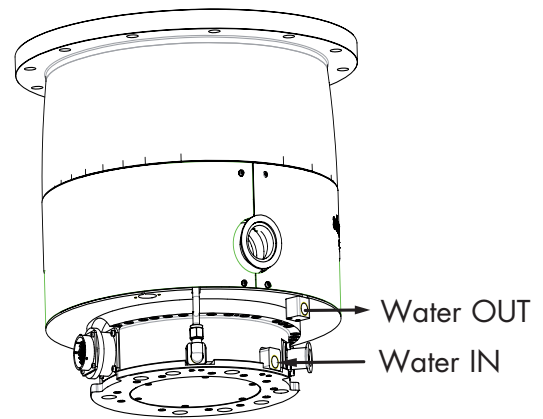



For ATH 2800-3200 MT models

- Provide a water inlet pipe and a tap to adjust the flow rate.

- Connect the water valve to the water inlet line using a flexible tube following the assembly diagram

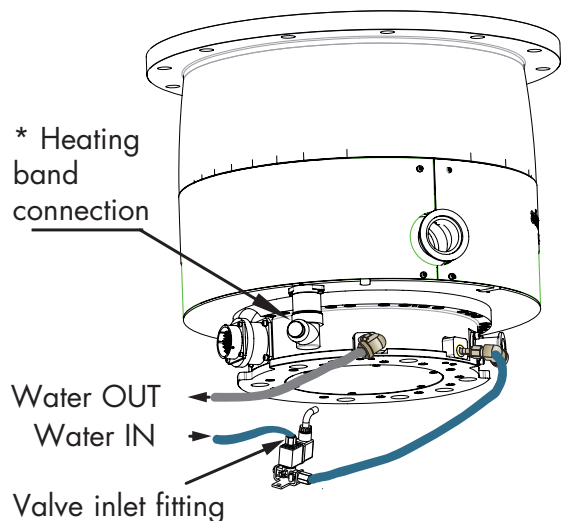
- Connect the other nipple to the draining circuit.



*  Heater band connection in the Operating instructions of controller.

For the pumps which work with the OBC controller, see the Operating instructions for the water valve connection.

For MT models

WARNING

These pumps are equipped with a heating band and a water valve. To guarantee the performance of the MT pump on difficult processes, make sure to :

- Connect the heating device, set the heating temperature via the controller (see Operating Instructions of the controller).

- Connect the water valve, check the efficiency of the cooling system and the absence of leaks. If stopping the cooling circuit creates a significant risk, install a «water sensor» security on the circuit.

Typical electrical wiring diagram

Typical connections

In this installation, we use:

- a roughing isolation valve **V1** between the turbo pump and the roughing pump;
- a high vacuum isolation valve **V2** between the turbo pump and the chamber to be pumped;
- a relay **K1**, their contacts drive the valve **V1** and the roughing pump power supply;
- the thermostatic option (MT pump model).

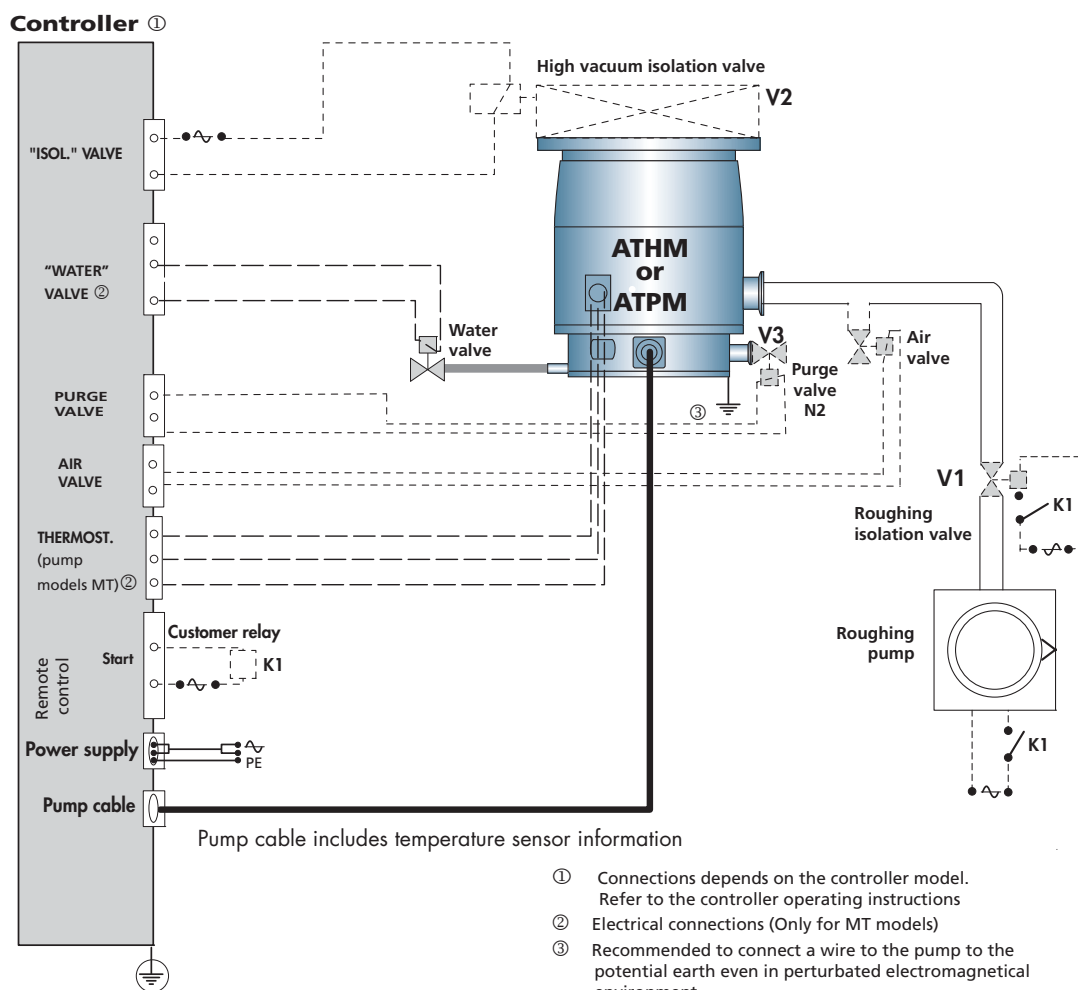

Wiring diagram (typical)

- ① Connections depends on the controller model. Refer to the controller operating instructions
- ② Electrical connections (Only for MT models)
- ③ Recommended to connect a wire to the pump to the potential earth even in perturbed electromagnetical environment

Legend: — Minimum electrical connections
 - - - Optional electrical connections recommended by the manufacturer (version M only)
 - - - Electrical connections (version MT only)

WARNING

We recommend that you fit a separate earth (ground) conductor to earth pump. Use an un-insulated braid or a separate insulated green/yellow conductor with a minimum 9AWG (3mm²) conductor (to comply with US and Canadian installation codes). Use a screw and a shakeproof washer fitted to the earth hole from the pump to secure the earth conductor to the pump. The impedance between the pump-body and the earth connection point must be < 0.1 Ohm at 25A.



Operation

ATH 2800 M/MT - ATH 3200 M/MT Operating instructions Detailed contents

C 100

Safety instructions for product use

Refer to the Magpower operating instructions to have information about pump operation

Safety instructions for product use

WARNING

Before using pump and controller, make sure that the mechanical and electrical connections have been made according to the safety recommendations: refer to chapter B from pump operating instructions and to associated controller operating instruction manual.

CAUTION

It is highly recommended to use:

- an inlet screen at the pump inlet;
- an isolation valve between the chamber to be pumped and the pump;
- an isolation valve between the pump and the roughing pump.

WARNING

■ Do not operate the pump until it is securely fixed. If the pump seizes, the stored energy of the rotor may cause further damage and injury to people. ( B300).



■ Risk of cut

The access to the rotor of a turbomolecular pump with an unconnected inlet port is dangerous. In the meantime, if the pump is not switched on, it may be driven by another pump in operation.

Always connect the pump inlet port before starting the pump.



■ Specific operating conditions may exist that require extra caution from users due to the high temperatures generated (outer surfaces > 70 °C): wear protective gloves and leave the pump to cool before working on the product.

■ Pump damage

Make sure that exhaust pipe line and pump internal parts are not clogged by process by-products (e.g. condensable products ...). If exhaust line is not clear, contact the customer service.

■ As loss of cooling water creates a significant risk for the pump, regularly check the right operation of the cooling circuit.

DANGER

■ Risk of injury by cutting.

The inlet of the pump mustn't be disconnected as long as the rotor is moving and without having disconnecting the power line cable.

WARNING

Risk of electrical shock.

The turbopump and the controller must only be disconnected from each other when the turbopump is completely at rest and the controller disconnected from the power supply.

Never unplug the pump by disconnecting the main cable. Only the authorized and trained technicians can perform intervention on the product.

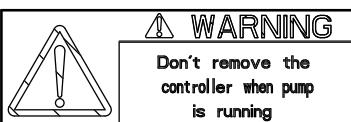

Located on the controller, this label indicates that the controller mustn't be disconnected when the pump is running.

Safety instructions for product use

WARNING

Standard precautions before any maintenance operations:

Before performing a maintenance operation, stop the pump. When the pump is at rest, switch off the pump by setting the controller main switch to «0», wait 5 minutes before disconnecting the main cable. If this last one remains connected, some components will still be energized.

Be sure that the controller status is visible from the operator otherwise disconnect the cable from the pump.

Refer to the controller Operating instructions to control and monitor the pump ( chapter C). Refer to the controller Operating instructions if a fault appears ( D 200).



Maintenance

ATH 2800 M/MT - ATH 3200 M/MT Operating instructions Detailed contents

D 100

Safety instructions for product removal

D150

Maintenance frequency

Safety instructions for product removal

WARNING

- Maintenance must be performed by a skilled maintenance operator trained in the relevant health and safety aspects (EMC, electrical hazards, chemical pollution, etc.).

Isolate the product from all energy sources (mains electricity, compressed air, water, gas ...) before starting work.

- Standard precautions before any maintenance operation:

Before performing a maintenance operation, stop the pump. When the pump is at rest, switch off the pump by setting the controller main switch to «0», wait 5 minutes before disconnecting the main cable. If this last one remains connected, some components will still be energized.

Be sure that the controller status is visible from the operator otherwise disconnect the cable from the pump.

- Risk of injury by cutting:

The inlet of the pump mustn't be disconnected as long as the rotor is moving and without having disconnected the power line cable.

- After pumping on corrosive or toxic gases, it is strongly recommended to seal the pump with blanking plates in case of return to the repair service centers ( E 100). Don't forget to label in a visible way the product for the operator.

DANGER

- Risk due to pumping conditions:

Remaining process gases in the pump may cause severe injury or death. Before removing the pump from the installation, continue N2 flow from the process tool for 30 min. Nitrogen pressure and flow rate should be identical to the programmed values during process.

- Chemical supplies coming from the tool, as well as the water and the nitrogen need also to be locked out / tagged out.

- During pump removal, operator could be in contact with process residues on the inlet and exhaust ports which could cause severe injury or death. Ask your safety department for instructions according to the local regulations.

Safety instructions for product removal

Users are advised:



Wear gloves, protective glasses, any appropriated safety equipment.
Ventilate the premises well.

Do not eliminate maintenance waste via standard disposal channels. Have it destroyed by a qualified company if necessary.

Install the inlet and exhaust blanking plates, thus delivered with the pump or available as accessories (📖 E100) .

The outside of the product and control box can be cleaned with a lint free wiper. Avoid using cleaning products that deteriorate printed surfaces and self adhesive labels. All other cleaning operations must be done by our service centers.

Decontamination – product dismantling

According to the regulations 2002/96/CE about Waste of electrical and electronical equipments, and 2002/95/CE about Restriction of Hazardous substances, the manufacturer provides a recycling paid service for the end-of-life of waste electrical and electronic equipment.

Any obligation of the manufacturer to take back such equipment shall apply only to complete not amended or modified equipment, using adixen Vacuum Products original spare parts, delivered by adixen Vacuum Products, containing i.e. all its components and sub-assemblies.

This obligation will not cover the shipping cost to an adixen Vacuum Products service center.

Before returning the product, fill in the declaration of contamination form available on our website, and refer to the service conditions (📖 G200). Attach it to the product before shipping to the service-repair office closest to you.

How to contact us ?

The overhaul must be performed by manufacturer's trained personnel. Contact nearest service center or the service support at the following e-mail address: support.service@adixen.fr

Maintenance frequency

Back-up ball bearings

When the pump is running, the rotor is levitated magnetically. There is therefore no friction between moving and fixed parts.

When the pump is stopped by the controller, the back-up ball bearings are not used. The rotor remains levitated by magnetic ball bearings.

Only the back-up ball bearings require maintenance: they are designed to withstand many accidental shut-downs, or many landings of the rotor on the ball bearings at full speed. These accidental shut-downs occur only in exceptional circumstances: broken power supply cable, strong shocks, faulty electronics. It is advisable to check the bearing counter and provide ball bearing maintenance, when needed.

The bearing counter

Back-up ball bearings are designed to withstand abnormal landings at full speed.

The wear of the back-up ball bearings is internally monitored by the controller, based on the rotation speed and the landing duration. Initial percentage value is set at 100 %. When this percentage reaches 0 %, an alarm is generated, pump can't restart, and back-up ball bearings need to be replaced by authorised Service Center.

Warning messages for pump maintenance

The ball bearing alert threshold can be set on the menu ( C300 on the controller Operating instructions).

If the ball bearings life time is smaller than the alert threshold, an alert message is displayed.

The troubleshooting is available in the controller Operating instructions ( D200).

The internal memory of the controller also informs the operator when the ball-bearings require maintenance (refer to the controller operating instructions).

CAUTION

The life time of the rotor is at least 5 years under normal conditions with clean process. Please contact the Service Center to check your application.

Product maintenance

The full overhaul must be performed by manufacturer's trained personnel.

Only controller replacement, inlet screen or pump valve replacement are authorized at the customer's site.

Contact nearest service center or the service support at the following e-mail address: support.service@adixen.fr.



Maintenance instructions

ATH 2800 M/MT - ATH 3200 M/MT

Operating instructions

Detailed contents

E 50

Replacement of the water valve coil

- Coil dismantling
- Coil reassembling

E 100

Shipping procedure for contaminated pumps

- Connecting ports
- Rough decontamination procedure
- General flushing
- Purge / inlet flushing
- Pressurize the pump

Replacement of the water valve coil

Coil dismantling Unscrew the M5 fitting of the valve and remove it.



Remove the spring clip.



Remove the coil and replace it by a new one.



Coil reassembling Put again the spring clip .

Install the new o'ring on the M5 fitting.



Stick the first threads of M5 fitting with Loctite 542* glue.



Screw the M5 fitting and tighten it slightly with a 14 mm open end wrench.



* Registered trade mark Loctite.

Shipping procedure for contaminated pumps

⚠ WARNING

Study the safety instructions related to preventive maintenance  D 100.



The user must stick this label on the product to warn against pumped process gas that could be dangerous and toxic and could cause severe injuries or death. It specifies that any preventive maintenance operation can only be performed by trained personnel.

Whenever you return the product to an Adixen repair service center, please make sure you follow the «procedure for returning products» and fill in the declaration of contamination (see our website, link Service).

⚠ WARNING

Risk of injury by cutting.
Contact with the pump rotor cell may cause cuts. Alternatively, protective gloves may be worn when servicing the product.

Pumps to be shipped must initially be decontaminated then pressurized with dry nitrogen (see procedure sheet 2/3).

Closing kits including O-ring, screws and nuts, inlet blank flange and hoisting rings can be supplied upon order.

Connecting ports

A Inlet port

*Closing kit	DN 200 ISO-F	DN 250 ISO-F	DN 320 ISO-F
P/N	108496	108497	114503

* depends on the pump

B Exhaust port DN 40 - ISO-KF

Description	DN 40	DN 50**
Centering ring with seal	068194	087164
DN 40 Clamping ring	083267	087163
Blank-off flange	068197	087162

** DN 50 ISO KF
(if available ordered in ordering guide)

C *** Purge port

DN16 - ISO KF		1/4 VCR	
Centering ring with DN 16 seal	068193	Seal	076705
DN 16 clamping ring	083333	Fitting 1/4 VCR female	108500

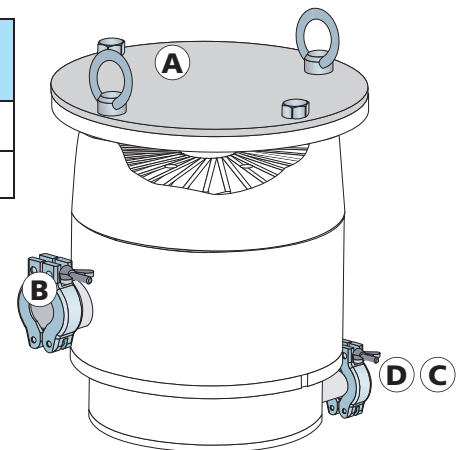

*** Standard connection accessories available in the product catalog.

Shipping procedure for contaminated pumps

D Purge port pressurisation

Note : Some pressurization kits including connecting accessories for inlet, exhaust and purge ports, plus an injector are available.

Description	P/N
DN 16 1/8 BSPT flange with anti-suckback valve including an injector	A458805
Injector	106859

Description	P/N
Kit for DN 200-ISO-F flange + Purge DN 16	108499
Kit for DN 250-ISO-F flange + Purge 1/4 VCR	108498

Rough decontamination procedure

The pump must be disconnected from its installation and isolated electrically.

DANGER

Install the pump under an extractor hood. It must remain there throughout the operation.

1 General flushing

Fit the DN 16 blank flange with anti-suckback valve on the purge connector (or 1/4 VCR).

Flush with dry nitrogen* using the injector at an absolute pressure of 110 to 150 kPa for 30 minutes.

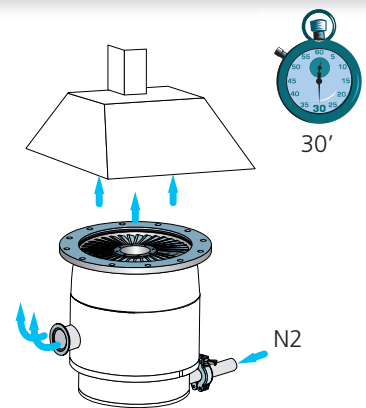

2 Purge / inlet flushing

Fit the DN 40 blank flange on the pump exhaust port.

Flush with dry nitrogen* for 10 minutes.

Stop the nitrogen flow.

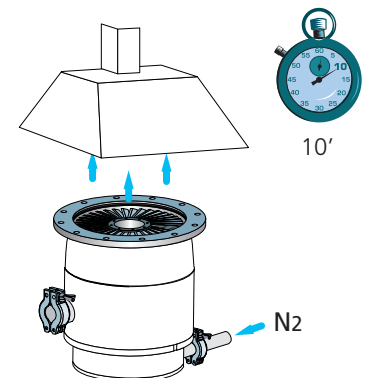

* Characteristics of dry nitrogen: B 330.

Shipping procedure for contaminated pumps

3 Pressurize the pump

Blank the inlet port and
exhaust port.

Pressurize the pump with
dry nitrogen* to an absolute
pressure of 110 kPa using the
injector.

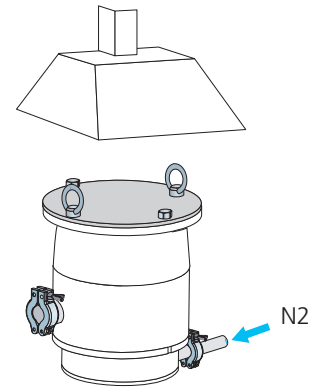

* Characteristics of dry nitrogen:  B 330.



Maintenance components

ATH 2800 M/MT - ATH 3200 M/MT

Operating instructions

Detailed contents

F 000

Spare parts - Instructions of use

- Replacement of parts and use of non genuine parts

F 100

First level maintenance parts

Spare parts - Instructions of use

Replacement of parts and use of non genuine parts

Our products are designed to comply with current EC regulations and guarantee optimal operating conditions with maximum safety conditions for the user.

Any modification of the product made by the user is liable to lead to non-compliance with the regulations, or even to put into doubt the performance of the product and the user's safety.

Replacement of defective components with parts that are not genuine, jeopardizes the initial safety conditions of the equipment.

In such cases, the EC declaration of conformity becomes null: The manufacturer withdraws responsibility for such operations.

Besides, counterfeiting and unfair trading of parts are condemned under civil and criminal laws.

The manufacturer urges the user not to use «imitation parts», or the misappropriation and pirating of intellectual property performed by some dishonest operators.

The manufacturer supplies maintenance components, spare parts or kits to perform the maintenance of its products ( F).

First level maintenance parts

**For air inlet
and purge valve**

	P/N
Coil 24 V DC	038066

Dust filter Replace regularly the dust filter
when used in dusty air

	P/N
Dust filter	106229

A complete range of connecting accessories is available in the manufacturer's catalogue (flanges, fittings...).

Water valve coil

	P/N
Coil 24 V DC	108667



Appendix

ATH 2800 M/MT - ATH 3200 M/MT Operating instructions Detailed contents

G 150

Pumping curves

G 200

Service

Pumping curves

PUMPING SPEED, ATH2800M DN250
 (without inlet screen and with 50 sccm purge)

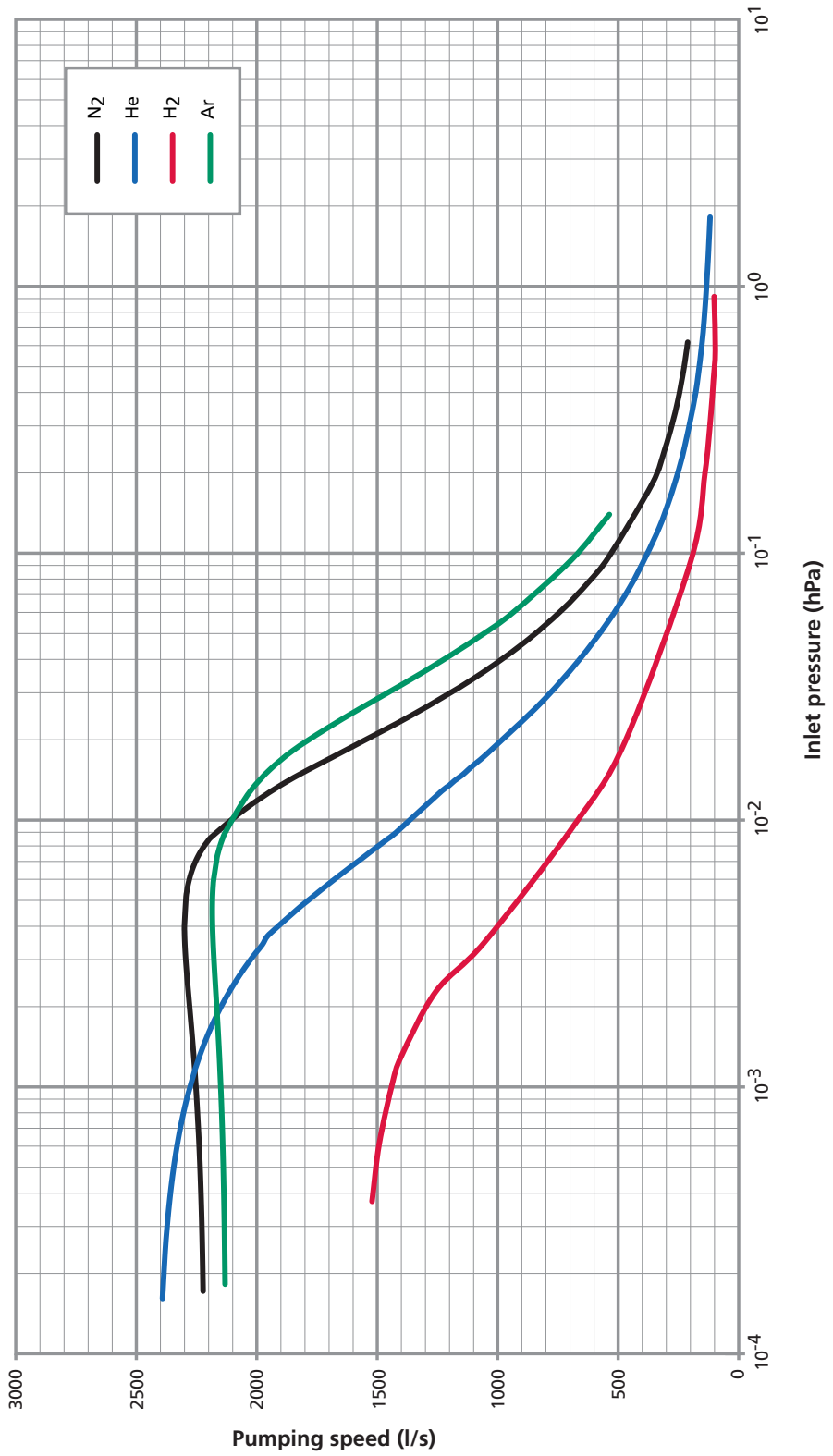

Pumping curves

PUMPING SPEED, ATH 3200 M DN320
(without inlet creen and with 50 sccm purge)

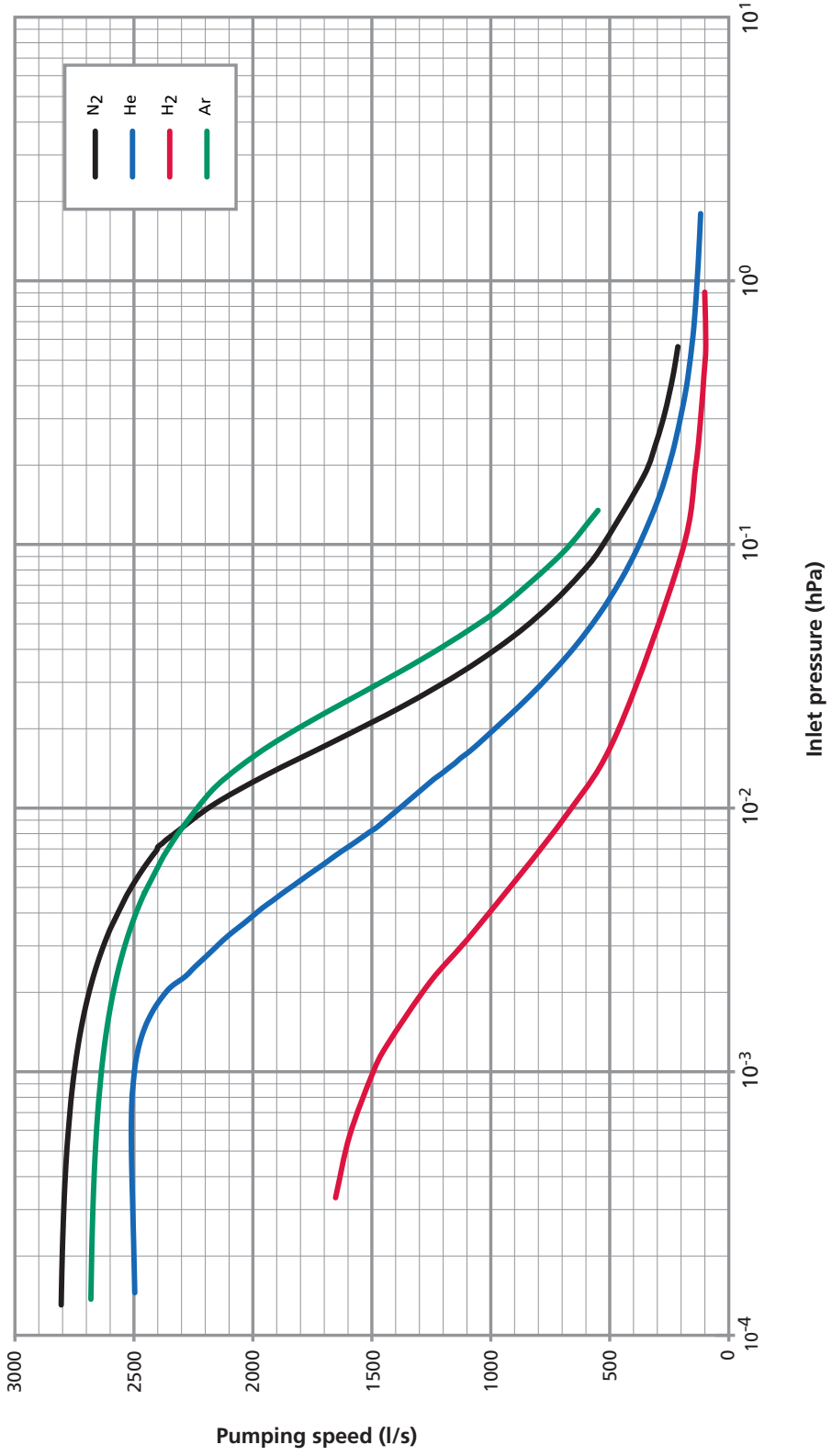

Service

Pfeiffer Vacuum offers first-class customer service!

- On-Site maintenance for many products)
- Overhaul / repair in the nearby Service Location
- Fast replacement with refurbished exchange products in mint condition
- Advice on the most cost-efficient and quickest solution

Detailed information, addresses and forms at: www.pfeiffer-vacuum.com (Service).

Overhaul and repair in the Pfeiffer Vacuum Service Center

The following general recommendations will ensure a fast, smooth servicing process:

- ➔ Fill out the «Service Request/Product return» form and send it to your local Pfeiffer Vacuum Service contact.
- ➔ Include the confirmation on the service request from Pfeiffer Vacuum with your shipment.
- ➔ Fill out the declaration of contamination and include it in the shipment (mandatory!). The Declaration of contamination is valid for any product/device including a part exposed to vacuum.
- ➔ Dismantle all accessories and keep them.
- ➔ Close all the ports flange openings by using the original protective covers or metallic airtight blank flanges for contaminated devices.
- ➔ If possible, send pump or unit in its original packaging.

Sending of contaminated pumps or devices

No devices will be accepted if they are contaminated with micro-biological, explosive or radioactive substances. "Hazardous substances" are substances and compounds in accordance with the hazardous goods regulations (current version).

- ➔ Neutralize the pump by flushing it with nitrogen or dry air.
- ➔ Close all openings airtight.
- ➔ Seal the pump or device in suitable protective film.
- ➔ Return the pump/device only in a suitable and sturdy transport container and send it in while following applicable transport conditions.

Pump or device returned without declaration of contamination form fully completed and/or non-secured in a suitable packaging, will be decontaminated and/or returned at the shipper's expense.

Exchange or repaired devices

The factory operating parameters are always preset with exchange or repaired devices. If you use specific parameters for your application, you have to set these again.

Service orders

All service orders are carried out exclusively according to our general terms and conditions for the repair and maintenance, available in our website.

**Vacuum Solutions
from a single Source**

Pfeiffer Vacuum stands for innovative and custom vacuum solutions worldwide, technological perfection, competent advice and reliable service.

**Complete range
of products**

From a single component to complex systems: We are the only supplier of vacuum technology that provides a complete product portfolio.

**Competence in
theory and practice**

Benefit from our know-how and our portfolio of training opportunities! We support you with your plant layout and provide first-class on-site service worldwide.

**Are you looking for a
perfect vacuum solution?
Please contact us:**

Pfeiffer Vacuum GmbH
Headquarters
T +49 6441 802-0
Info@pfeiffer-vacuum.de

