

# Sales Quotation Number NIK-001-1120



**CUSTOMER: NIKHEF**

**Deliver to:**

**Customer No: N/A**

Antonio Pellegrino  
[antonio@nikhef.nl](mailto:antonio@nikhef.nl)

Netherlands - TBC

Quote valid 60 days from date  
 Prices excludes local sales taxes and duties

Complete Connect Ltd  
 UNIT 16  
 SOUTHDOWN DRIVE  
 LONDON  
 SW20 8EZ  
**Tel: +44 (0)20-8286-6529**  
**Date: 18/11/2020**

## M2400 Series

Part Number	Description	UOM	Lead Time **	QTY	Price	TOTAL
<b>M2003-SFSF-48LS-PC-004-A *</b>	M2000 Series Trunk Cable MTP (female) – MTP (female) OM3 (50/125) 48 fibre micro core (4.8mm) single sheath cable with 12 fibre sub-units LSZH; Polarity A; Total Length – 4m MTP 48 fibre connectors Note – Total Length measured to end-face	EACH	10 Days	2	€151.17	€302.34
<b>M314-24LCQ-1U-PANEL *</b>	M310 Series 1U 96 Fibre MTP Panel Rear Connectivity - MTP (male) Standard 48 fibre (x2) Front Connectivity - LC QUAD PREMIUM (x24) MTP Standard 48 Fibre Connectors; Polarity A/C	EACH	4 Weeks	1	€479.95	€479.95
<b>M1004-EFEF-24LS-PC-004-X *</b>	M1000 Series SR10 Patch Cable MTP (female) – MTP (female) OM4 (50/125) 24 fibre micro core (3.8mm) single sheath cable LSZH; Total Length – 4m; Polarity X; MTP ELITE 24 fibre connectors	EACH	10 Days	4	€89.01	€356.04
<b>M314-24LCQ-1U-PANEL *</b>	M310 Series 1U 96 Fibre MTP Panel Rear Connectivity - MTP (male) ELITE 24 fibre (x4) Front Connectivity - LC QUAD PREMIUM (x24) MTP ELITE 24 Fibre Connectors; Polarity A/C	EACH	4 Weeks	1	€489.35	€489.35
<b>M2404-SFEF(4)-48LS-CC-004-(100) *</b>	M2400 Conversion Cable MTP (48 fibre) – MTP (12 fibre x4) OM4 (50/125) 48 fibre micro core round (10.0mm) single outer sheath cable with 12 fibre sub-units LSZH; Total Length – 4m; MTP (12 fibre) Tail Length – 1 m (no stagger); Polarity – Custom	EACH	10 Days	1	€204.65	€204.65
<b>M2404-SFEF(2)-48LS-CC-004-(100) *</b>	M2400 Conversion Cable MTP (48 fibre) – MTP (24 fibre x2) OM4 (50/125) 48 fibre micro core round (10.0mm) single outer sheath cable with 12 fibre sub-units LSZH; Total Length – 4m; MTP (24 fibre) Tail Length – 1 m (no stagger); Polarity – Custom	EACH	10 Days	1	€219.92	€219.92

<b>M314-24LCQ-1U-PANEL *</b>	M310 Series 1U 96 Fibre MTP Panel Rear Connectivity - MTP (male) ELITE 12 fibre (x8) Front Connectivity - LC QUAD PREMIUM (x24) MTP ELITE 12 Fibre Connectors; Polarity A/C	EACH	4 Weeks	1	€484.43	€484.43	
						<b>Delivery</b>	<b>€TBC</b>
						<b>TOTAL</b>	<b>€TBC</b>

\* made-to-order; \*\* lead times for order taken after 1pm begin on the next working day. (Lead times are estimates, in working days and to date of despatch)

### M2000 Series 48 Fibre Trunk Cable:

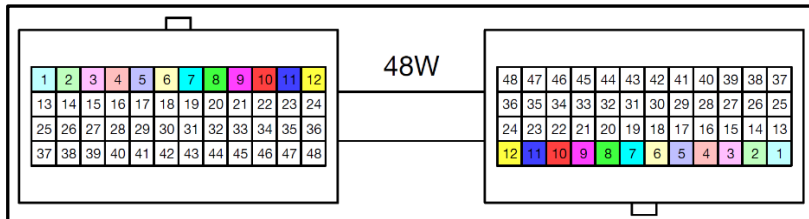

Polarity A

Top is nearest Key

- Row 1 (top row): End A fibre 1 connected to End 2 fibre 1, End A fibre 2 connected to End 2 fibre 2.... End A fibre 12 connected to End 2 fibre 12
- Row 2 (2<sup>nd</sup> row from top): End A fibre 13 connected to End 2 fibre 13, End A fibre 14 connected to End 2 fibre 14.... End A fibre 24 connected to End 2 fibre 24
- Row 3 (3<sup>rd</sup> row from top): End A fibre 25 connected to End 2 fibre 25, End A fibre 26 connected to End 2 fibre 26.... End A fibre 36 connected to End 2 fibre 36
- Row 4 (Bottom row): End A fibre 37 connected to End 2 fibre 37, End A fibre 38 connected to End 2 fibre 38.... End A fibre 48 connected to End 2 fibre 48

### M1000 Series 24 Fibre Trunk Cable:

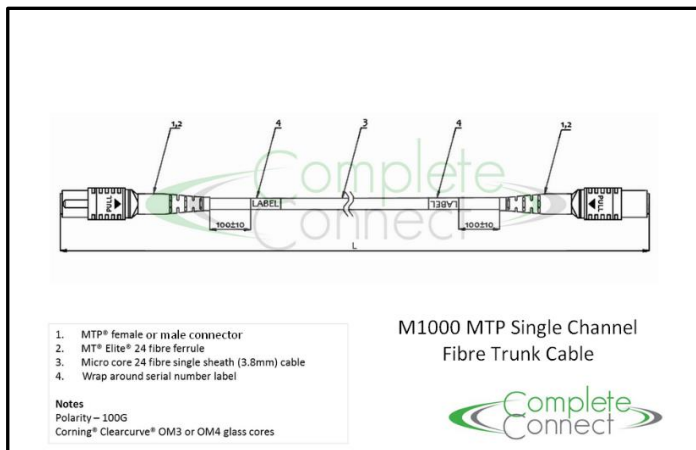

## M310 Series High Density MTP – LC Patch Panels:

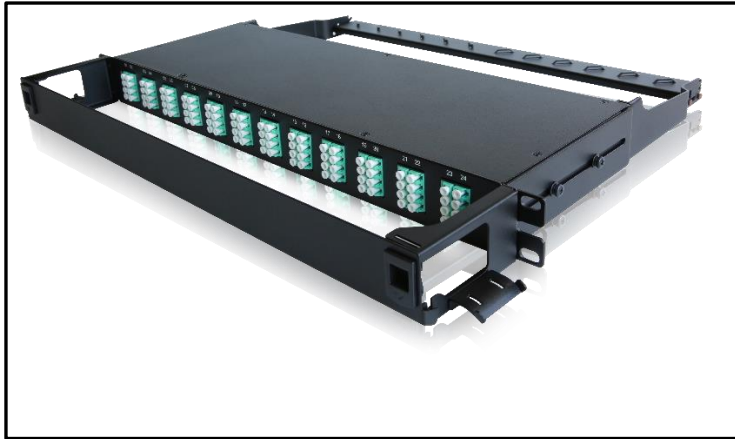

Front:

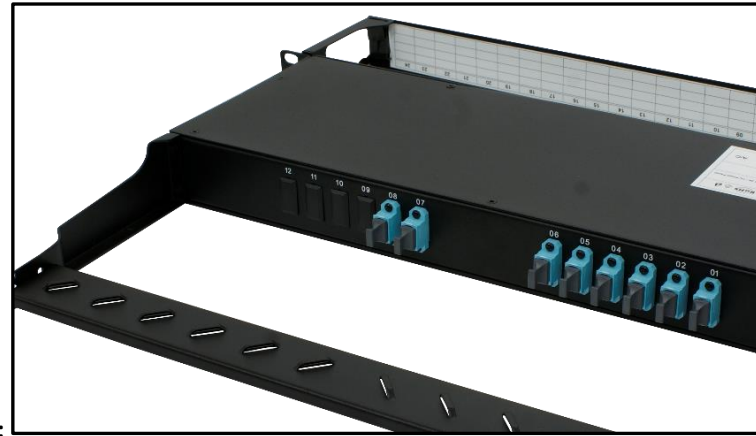

Rear:

## M2400 Series Conversion Cable 1x48f to 2x24f:

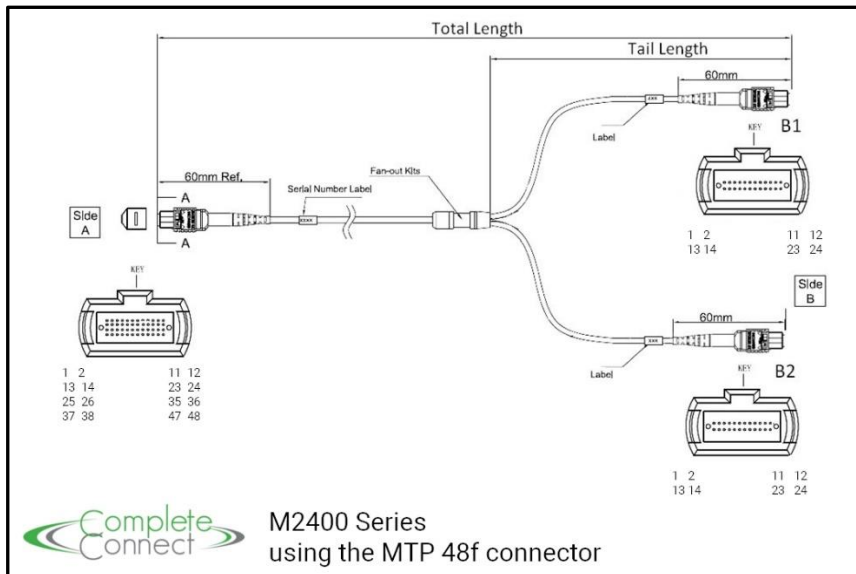

## M2400 Series Conversion Cable 1x48f to 4x12f:

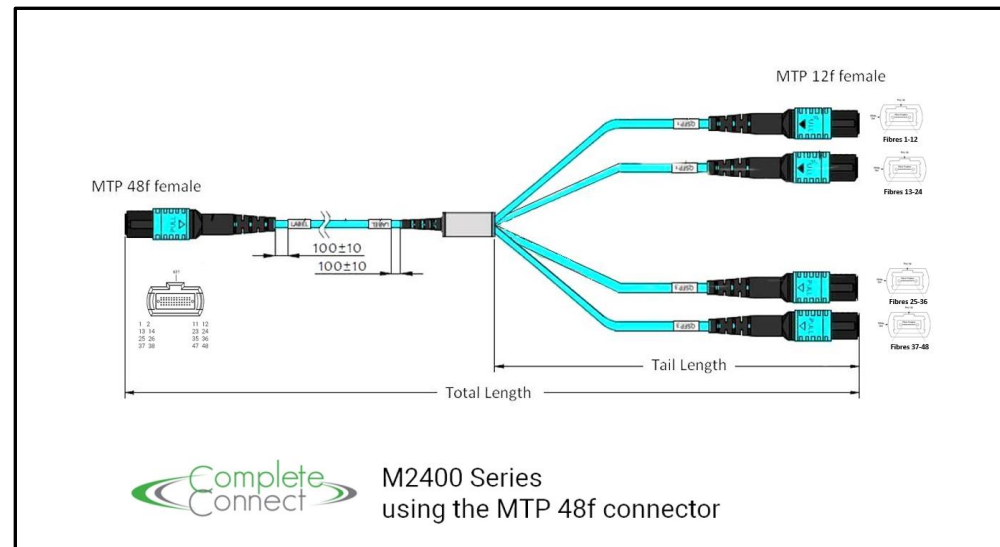

## Personal Data Collection and Storage

Please note that in order to provide support or services to you we will collect and store your personal data. This data may include your email address, name, company name and phone number, but also other personal data. We do not pass your details on to other companies to use for marketing or data analysis, however we use 3<sup>rd</sup> party companies to store data for our use. We may use your name and email address to send you relevant information about our products and services. You can unsubscribe to these emails at any time. All marketing emails contain an unsubscribe link or you can email [sales@completeconnect.co.uk](mailto:sales@completeconnect.co.uk).

For further information, please see our privacy policy, [completeconnect.co.uk/privacy-policy](https://completeconnect.co.uk/privacy-policy)

## Terms and Conditions of Sale and Quote

- 1.1. Products that are **made-to-order** are non-cancellable and non-refundable
- 1.2. For **made-to-order** products the lead time will be confirmed at point of ordering.
- 1.3. Where applicable, products are supplied with full test certificates
- 1.4. This Sales Quotation is subject to our Company's standard terms and conditions
- 1.5. Despatch of any order may be delayed if there are overdue invoices outstanding on the account
- 1.6. All prices ex VAT or local taxes

## Complete Connect Terms and Conditions of Sale

### 1. Definitions

- 1.1. 'Business Day' means: a day (other than a Saturday, Sunday or public holiday) when banks in London are open for business.
- 1.2. 'Company' means Complete Connect Ltd, trading as Complete Connect.
- 1.3. 'Conditions' means the terms and conditions of sale set out in this document and any special terms and conditions agreed in writing by the Company.
- 1.4. 'Contract' means the contract between the Company and the Purchaser for the purchase of the Goods in accordance with these Conditions.
- 1.5. 'Delivery Date' means when the Goods are to be delivered in accordance with the Contract.
- 1.6. 'Force Majeure Event' has the meaning given in clause 11
- 1.7. 'Goods' means the articles which the Purchaser agrees to buy from the Company, as described in a quotation.
- 1.8. 'Order' means the Customer's order for the Goods, as set out in the Customer's purchase order form or in the Customer's written acceptance of the Company's quotation, as the case may be.
- 1.9. 'Price' means the price for the Goods excluding carriage, packing, insurance and VAT.
- 1.10. 'Purchaser' means the person who buys or agrees to buy the Goods from the Company.

### 2. Conditions applicable

- 2.1. These Conditions shall apply to all contracts for the sale of Goods by the Company to the Purchaser to the exclusion of any other terms that the Customer seeks to impose or incorporate, or which are implied by trade, custom, practice or course of dealing.
- 2.2. The Order shall constitute an offer by the Purchaser to purchase Goods pursuant to these Conditions.
- 2.3. The Order shall only be deemed to be accepted when the Company issues a written acceptance of the order, at which point the Contract shall come into existence.
- 2.4. Any variation to these Conditions (including any special terms and conditions agreed between the parties) shall be inapplicable unless specifically agreed in writing by a director of the Company.

- 2.5. The Contract constitutes the entire agreement between the parties. The Purchaser acknowledges that it has not relied on any statement, promise or representation made or given by or on behalf of the Company which is not set out in the Contract.
- 2.6. Statements or representations of whatever kind and however made, including but not limited to those as to weights, measurements, performance, descriptions, details of design, prices, charges and whether contained in catalogues, advertisements, brochures, photographs, descriptive materials, verbal representations or otherwise are approximate only and shall not be binding upon the Company.
3. **The Price and payment**
  - 3.1. Where the Company is asked to give a quotation then the Price of the Goods shall be the Company's quoted price which shall be binding upon the Company provided that the Purchaser shall accept the Company's quotation within 30 days. If no price is quoted, the price set out in the Company's published price list in force as at the date of delivery shall be the Price. The Price is exclusive of VAT and the Purchaser shall, on receipt of a valid VAT invoice from the Company, pay to the Company such additional amounts in respect of VAT as are chargeable on the supply of the Goods.
  - 3.2. The Purchaser shall pay the Price and VAT in full and in cleared to the bank account nominated by the Company within 30 days of the date of the invoice. Time for payment is of the essence. The Company shall not be bound to deliver the Goods until the Purchaser has paid for them.
  - 3.3. Interest on overdue invoices shall accrue and be payable by the Purchaser from the date when payment becomes due on a daily basis until the date of payment at a rate of 4% above Lloyds Bank plc's base rate from time to time in force and shall accrue at such a rate after as well as before any judgment.
  - 3.4. The Purchaser shall pay all amounts due under the Contract in full without any deduction or withholding except as required by law and the Purchaser shall not be entitled to assert any credit, set-off or counterclaim against the Company in order to justify withholding payment of any such amount in whole or in part. The Company may at any time, without limiting any other rights or remedies it may have, set off any amount owing to it by the Purchaser against any amount payable by the Company to the Purchaser.
  - 3.5. If the Purchaser fails to make any payment on the due date then without prejudice to any of the Company's other rights the Company may:-
    - 3.5.1. suspend or cancel deliveries of any articles due to the Purchaser under this or any contract; and/or
    - 3.5.2. appropriate any payment made by the Purchaser to such of the Goods (including any Goods supplied under any other contract with the Purchaser) as the Company may in its sole discretion think fit;
  - 3.6. Prices are the Company's ex-works prices and where the Company agrees to arrange for the Goods to be sent to the Purchaser then unless otherwise agreed by the Company the Purchaser shall be responsible for the costs of loading, carriage and unloading.
4. **The Goods**
  - 4.1. The quantity and description of the Goods shall be as set out in the Company's quotation or catalogue, whichever is appropriate.
  - 4.2. The Company may from time to time make changes in the specification of Goods which are required to comply with any applicable safety or statutory requirements or which do not materially affect the quality or fitness for purpose of the Goods.
5. **Warranties and liability**
  - 5.1. The Company warrants that the Goods will at the time of delivery correspond to the description given by the Company as described in clause 4.1.
  - 5.2. Except where the Purchaser is dealing as a consumer (as defined in the Unfair Contract Terms Act 1977 Section 12) all other warranties, conditions or terms relating to fitness for purpose, satisfactory quality or condition of the Goods and whether implied by statute or common law or otherwise are excluded and under no circumstances shall the Company be liable for loss of profit or other indirect loss.
  - 5.3. The terms implied by sections 13 to 15 of the Sale of Goods Act 1979 are, to the fullest extent permitted by law, excluded from the Contract.
  - 5.4. Where the Purchaser gives notice to the Company within 24 hours of delivery that the Goods do not comply with the warranty in clause 5.1, and the Company is given the opportunity to inspect the Goods and the Purchaser returns the Goods to the Company at the Purchaser's cost, the Company shall, at its option, either repair or replace the defective Goods or refund the price of the defective Goods in full.
  - 5.5. The Company shall not be liable for the Goods' failure to comply with the warranty in clause 5.1 where any of the following apply:
    - 5.5.1. The Purchaser makes any further use of the Goods after giving notice in accordance with clause 5.4;
    - 5.5.2. The defect arises because the Purchaser failed to follow the Company's oral or written instructions as to storage, commission, installation, use and maintenance of the Goods or (if there were none) good trade practice regarding the same. he Customer alters or repairs such Goods without the written consent of the Supplier;
    - 5.5.3. the defect arises as a result of fair wear and tear, wilful damage, negligence, or abnormal storage or working conditions; or
    - 5.5.4. the Goods differ from their description as a result of changes made to ensure they comply with applicable statutory or regulatory requirements.
  - 5.6. Except as provided in this clause 5, the Company shall have no liability to the Purchase in respect of the Goods' failure to comply with the warranty set out in clause 5.1. In particular, and without limitation to the generality of the foregoing, under no circumstances will the Company be liable for any loss or damage arising from the Goods being used in an environment for which they were not intended, including without limitation on aircraft missiles, or for aviation or aerospace purposes, or for the safety or navigation of marine craft of any sort or for any other hazardous purpose.
6. **Cancellations**

No cancellation or suspension will be valid without the prior consent of the Company. No cancellation whatsoever will be accepted by the Company for non-standard goods ordered specially for the Customer.
7. **Delivery of the Goods**
  - 7.1. Delivery of the Goods shall be made at the Company's address on the Delivery Date. Unless otherwise agreed by the Company the Purchaser shall make all arrangements necessary to take delivery of and to transport the Goods whenever they are intended for delivery.
  - 7.2. The Company may deliver the Goods by separate installments. Each separate installment shall be invoiced and paid for in accordance with the provisions in these conditions.
  - 7.3. The failure of the Purchaser to pay for any one or more of the said installments of the Goods on the due dates shall entitle the Company (at the sole option of the Company):-
    - 7.3.1. without notice to suspend further deliveries of the Goods pending payment by the Purchaser; and/or
    - 7.3.2. to treat the contract as repudiated by the Purchaser;

- 7.4. The risk in the Goods shall pass to the Purchaser upon delivery.
8. **Acceptance of the Goods**
- 8.1. The Purchaser shall be deemed to have accepted Goods 24 hours after delivery to the Purchaser.
- 8.2. After acceptance the Purchaser shall not be entitled to reject Goods which are not in accordance with the contract.
- 8.3. Any discrepancy between the Goods and the Company's packing note must be notified to the Company within 24 hours of their arrival at the Purchaser's delivery address.
- 8.4. No Goods delivered to the Purchaser which are in accordance with the contract will be accepted for return without the prior written approval of the Company in accordance with the Company's returns authorization procedure and on terms to be determined at the absolute discretion of the Company.
- 8.5. If the Company agrees to accept any such Goods for return, the Purchaser shall be liable to pay a handling charge of 20% of the invoice price. Such Goods must be returned by the Purchaser carriage paid to the Company in their original shipping carton and with their original packing material.
- 8.6. Goods returned without the prior written approval of the Company may at the Company's absolute discretion be returned to the Purchaser or stored at the Purchaser's cost without prejudice to any rights or remedies the Company may have.
- 8.7. Any Goods properly rejected by the Purchaser shall be returned forthwith to the Company for testing and if such Goods are found to be faulty the Company may in its sole discretion elect either to replace the Goods or issue a credit note, either of which options shall be in full satisfaction of the Company's liability to the Purchaser.
- 8.8. Any rejected Goods subsequently found by the Company not to be faulty shall be paid for by the Purchaser in addition to any replacement Goods supplied and the provisions of clause 8.5 herein shall apply.
9. **Retention of Title**
- 9.1. Notwithstanding that risk in the Goods shall pass to the Purchaser upon delivery full legal and equitable title and interest in all and any Goods shall remain in the Company and shall not pass to the Purchaser until the Company shall have received payment in full of all amounts due and owing from the Purchaser to the Company for the time being (including any interest accruing and owing to the company) and from time to time in respect of such Goods and all other Goods supplied by the Company to the Purchaser at any time
- 9.2. During such time as title in the Goods remains in the Company the Purchaser shall store or otherwise keep the Goods in such a way as clearly to indicate at all times that the Goods are owned by the Company and shall not remove obscure or delete any mark placed on the Goods by the Company which may enable the Goods to be identified.
- 9.3. In the event of any dispute arising as to the ownership of any of the Goods sold under this or any other contract between the parties, title shall be presumed not to have passed unless the Purchaser proves to the contrary.
- 9.4. If the Purchaser shall sell any of the Goods it shall hold all the proceeds of sale as trustee for the Company and shall (until payment of amounts due to the Company) place such proceeds in a separate bank account and hold the same to the order of the Company and if the Purchaser shall sell any goods incorporating the Goods it shall hold so much of the proceeds of sale as relate to the Goods as trustee for the Company and shall (until payment of amounts due to the Company) place such proceeds in a separate bank account and hold the same to the order of the Company
- 9.5. Upon any such sale by the Purchaser of the Goods or goods incorporating the Goods all rights which the Purchaser may have against the purchaser of them shall automatically vest in the Company. The Purchaser shall indemnify and keep indemnified the Company in respect of any proceedings action or claim of any nature whatever made or brought by the said purchaser against the Company in respect of the Goods or any of them
- 9.6. Without prejudice to any other rights or remedies arising out of any breach of contract by the Purchaser the Company shall until payment for the Goods be entitled to repossess all or any of the Goods and to take possession of all or any of the goods incorporating such Goods.
- 9.7. For the purpose of any repossession pursuant to sub-clause 9.6 the Company or its agent shall be entitled to enter upon any relevant land or buildings with such transport as may be necessary and all costs incurred by the Company shall be borne by the Purchaser.
10. **Remedies of Purchaser**
- 10.1. Where the Purchaser rejects any Goods then the Purchaser shall have no further rights whatever in respect of the supply to the Purchaser of such Goods or the failure of the Company to supply Goods which conform to the contract of sale.
- 10.2. Where the Purchaser accepts or has been deemed to have accepted any Goods then the Company shall have no liability whatever to the Purchaser in respect of those Goods.
- 10.3. In the event that the Purchaser incorrectly rejects the Goods or any part then the Company shall be entitled to charge to the Purchaser any handling charge and any other loss or expense which it suffers as a consequence thereof.
- 10.4. Any returned Goods shall be accompanied by the Company's sales order number, the specific invoice number and the date upon which the Purchaser received the Goods, failing which the Company shall be under no liability whatsoever.
- 10.5. The Company shall not be liable to the Purchaser for late delivery or short delivery of the Goods
- 10.6. The Company shall be under no liability whatever to the Purchaser to any indirect or direct loss and/or expense (including loss of profit) suffered by the Purchaser arising out of a breach by the Company of these conditions and any contract made thereunder.
- 10.7. In the event of any breach of these conditions and any contract made hereunder by the Company the remedies of the Purchaser shall be limited to damages. Under no circumstances shall the liability of the Company exceed the price of the Goods
11. **Force majeure**
- Neither party shall be liable for any failure or delay in performing its obligations under the Contract to the extent that such failure or delay is caused by a Force Majeure Event. A 'Force Majeure Event' means any event beyond a party's reasonable control, which by its nature could not have been foreseen, or, if it could have been foreseen, was unavoidable, including strikes, lock-outs or other industrial disputes (whether involving its own workforce or a third party's), failure of energy sources or transport network, acts of God, war, terrorism, riot, civil commotion, interference by civil or military authorities, national or international calamity, armed conflict, malicious damage, breakdown of plant or machinery, nuclear, chemical or biological contamination, sonic boom, explosions, collapse of building structures, fires, floods, storms, earthquakes, loss at sea, epidemics or similar events, natural disasters or extreme adverse weather conditions, or default of suppliers or subcontractors.

# Sales Quotation Number NIK-001-1120



- 12. Notices.**
- 12.1. Any notice or other communication given to a party under or in connection with the Contract shall be in writing, addressed to that party at its registered office (if it is a company) or its principal place of business (in any other case) or such other address as that party may have specified to the other party in writing in accordance with this clause, and shall be delivered personally, sent by pre-paid first class post, recorded delivery, commercial courier, fax or e-mail.
- 12.2. A notice or other communication shall be deemed to have been received: if delivered personally, when left at the address referred to in 8; if sent by pre-paid first class post or recorded delivery, at 9.00 am on the third Business Day after posting; if delivered by commercial courier, on the date and at the time that the courier's delivery receipt is signed; or, if sent by fax or e-mail, one Business Day after transmission.
- 12.3. The provisions of this clause shall not apply to the service of any proceedings or other documents in any legal action.
- 13. Severance.**
- 13.1. If any court or competent authority finds that any provision of the Contract (or part of any provision) is invalid, illegal or unenforceable, that provision or part-provision shall, to the extent required, be deemed to be deleted, and the validity and enforceability of the other provisions of the Contract shall not be affected.
- 13.2. (b) If any invalid, unenforceable or illegal provision of the Contract would be valid, enforceable and legal if some part of it were deleted, the provision shall apply with the minimum modification necessary to make it legal, valid and enforceable.
- 14. Waiver.**
- A waiver of any right or remedy under the Contract is only effective if given in writing and shall not be deemed a waiver of any subsequent breach or default. No failure or delay by a party to exercise any right or remedy provided under the Contract or by law shall constitute a waiver of that or any other right or remedy, nor shall it preclude or restrict the further exercise of that or any other right or remedy. No single or partial exercise of such right or remedy shall preclude or restrict the further exercise of that or any other right or remedy.
- 15. Third party rights.**
- A person who is not a party to the Contract shall not have any rights under or in connection with it.
- 16. Variation.** Except as set out in these Conditions, any variation to the Contract, including the introduction of any additional terms and conditions, shall only be binding when agreed in writing and signed by a director of the Company.
- 17. Proper law**
- The Contract, and any dispute or claim arising out of or in connection with it or its subject matter or formation (including non-contractual disputes or claims), shall be governed by, and construed in accordance with, English law, and the parties irrevocably submit to the exclusive jurisdiction of the courts of England and Wales. save that the Company may take protective proceedings in any jurisdiction it deems necessary to protect its interests.